

CONTENTS

FULL-COVER TYPE BALLSCREW ACTUATORS/SC SERIES

Variations, Model No.	100
Specifications	101
Accuracy	102
Inertia	103
SC23 Long block configuration	104
Long block configuration, dimensions, permissible speed and mass	105
Sub guide rail configuration	106
Sub guide rail configuration, dimensions, permissible speed and mass	107
Cover configuration	108
Sensors and sensor rails	109
(Note) For motor bracket configurations, refer to pages 68 to 71 in SE series section.	
SC30 Long block configuration	110
Long block configuration, dimensions, permissible speed and mass	111
Sub guide rail configuration	112
Sub guide rail configuration, dimensions, permissible speed and mass	113
Cover configuration	114
Sensors and sensor rails	115
(Note) For motor bracket configurations and parallel motor mounting, refer to pages 78 to 81 in SE series section.	
SC45 Long block configuration	116
Long block configuration, dimensions, permissible speed and mass	117
Sub guide rail configuration	118
Sub guide rail configuration, dimensions, permissible speed and mass	119
Cover configuration	120
Sensors and sensor rails	121
(Note) For motor bracket configurations and parallel motor mounting, refer to pages 92 to 95 in SE series section.	
Sensor specifications - Photo-microsensor S, M, Y	122
Sensor specifications - Proximity sensor K, E	123
Sensor specifications - Photo-microsensor C, P, H, J	124

SG

SG20

SG26

SG33

SG46

SG55

SE

SE15

SE23

SE30

SE45

SC

SC23

SC30

SC45

Sensor

Technical Data

VARIATIONS

Model No.	SC23	SC30	SC45	
Performance grade	H: Repeated positioning accuracy $\pm 3\mu\text{m}$ ^{(Note 1) (Note 2)}			
	U: Repeated positioning accuracy $\pm 5\mu\text{m}$ ^(Note 2)			
	W: Repeated positioning accuracy $\pm 10\mu\text{m}$ ^(Note 2)			
Screw shaft dia. (mm)	8	10	15	
Lead (mm)	2	●		
	4	●	○	
	5	○	○	○
	6		○	
	8	●		
	10		○	○
	20		○	○



○: In-stock items ●: Manufactured by order

(Note 1) There is no Performance Grade H in SC30 leads 6mm and 20mm.

(Note 2) Performance may be different from the values shown above, depending on applied options and usage.

HOW TO INTERPRET MODEL NO.

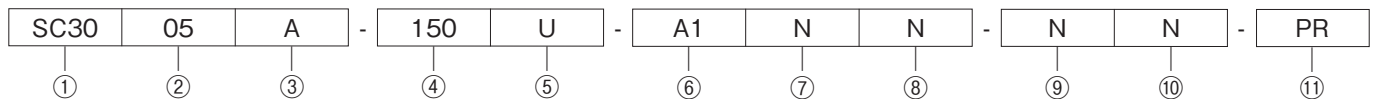

① Model ② Lead

① Model	② Lead	② Sub guide rail
SC23	2, 5	SB
SC30	4, 5, 6, 10, 20	SB
SC45	5, 10, 20	SB

③ Slide block

Model	Slide block
SC23	
SC30	A: With 1 long block
SC45	E: With 1 long block (LUBSEAL)

④ Guide rail length ^{(Note 1) (Note 2)}

Model	Guide rail length (mm)
SC23	150, 200, 250, 300
SC30	150, 200, 300, 400, 500, 600, 700*, 750*
SC45	540, 640, 740, 840, 940

⑤ Performance grade ^(Note 3)

H	Repeated positioning accuracy $\pm 3\mu\text{m}$
U	Repeated positioning accuracy $\pm 5\mu\text{m}$
W	Repeated positioning accuracy $\pm 10\mu\text{m}$
L	Sub guide rail

⑥ Motor bracket configuration

Model	Motor bracket configuration	Sub guide rail
SC23	A0, A1, A2, A3, A5, A6, A7	NN
SC30	A0, A1, A2, A3, A4, A5, A7, B1, RN, E□, F□	NN
SC45	A0, A1, A2, A3, A4, A5, A6, RN, E□, F□, G□	NN

⑦ Type of cover

N	Standard cover
G	With grease nipple
S	With wiper
D	With grease nipple and wiper

⑧ Sensor

Model	Sensor
SC23	N: Without sensor
	S: Photo-microsensor
	K, E: Proximity sensor
	1: For sensor rails only
SC30	N: Without sensor
	M, Y, C, P: Photo-microsensor
	K, E: Proximity sensor
SC45	1: For sensor rails only

⑨ Surface treatment ^(Note 4)

N	Standard treatment
L	Anti corrosive black coating

⑩ Grease ^(Note 5)

Model	Grease
SC23	N: Standard grease
SC30	S: Dust preventive
SC45	KURODA S grease

⑪ Additional options

Blank	No dowel pin hole
PR	For guide rail only
ML	For reversed guide rail reference surface
MPR	For both reversed guide rail reference surface and guide rail

(Note 1) For specifications of guide rail with long rails or intermediate stroke with non-standard length, consult KURODA.

(Note 2) The SC30 rail lengths marked with "*" are not available in Performance Grade H.

(Note 3) There is no Performance Grade H in SC30 leads 6mm and 20mm.

(Note 4) With standard specifications of surface treatment (Symbol: N), only guide rails are treated with black coating.

(Note 5) With standard grease (Symbol: N), Multemp PS No.2 Grease (KYODO YUSHI CO., LTD.) is contained in slide block and ball screw components.

(Note 6) With Lubrication unit LUBSEAL specifications refer to Front matters 14 to 15.

SPECIFICATIONS

Model no.				SC2302	SC2305	SC3004	SC3005	SC3006	SC3010	SC3020	SC4505	SC4510	SC4520		
Performance grade				W	U	H	W	U	H	W	U	H	W	U	H
Guide	Radial clearance		μm	-3~0			-3~0			-5~0					
	Long block	Basic dynamic load rating	C	kN			4.3			7			27		
		Basic static load rating	C_0	kN			7.0			11.8			45.0		
		Static permissible moment	M_P	N·m			29			43			68		
			M_Y	51			107			194					
M_R	61			84			250								
Ball screw	Shaft diameter		mm	8			10			15					
	Lead		mm	2	5	4	5	6	10	20	5	10	20		
	Basic dynamic load rating	C_a	kN	1.8	1.9	3.0	3.0	3.0	2.0	2.2	5.1	5.1	3.1		
	Basic static load rating	C_{0a}	kN	3.2	3.1	5.3	5.3	5.3	3.2	3.5	10.5	10.5	6.6		
Fixed side bearing	Model No. of bearing			AC6-16DF or equivalent			708DFP5 or equivalent			5201A or equivalent					
	Basic dynamic load rating	C_b	kN	1.79			4.40			5.90					
	Basic static load rating	C_{0b}	kN	1.76			4.36			3.20					

(Note 1) Static permissible moment shows rigidity value based on dimensions and material of table.

(Note 2) There is no Performance Grade H in SC30 leads 6mm and 20mm.

DIRECTION OF MOMENT

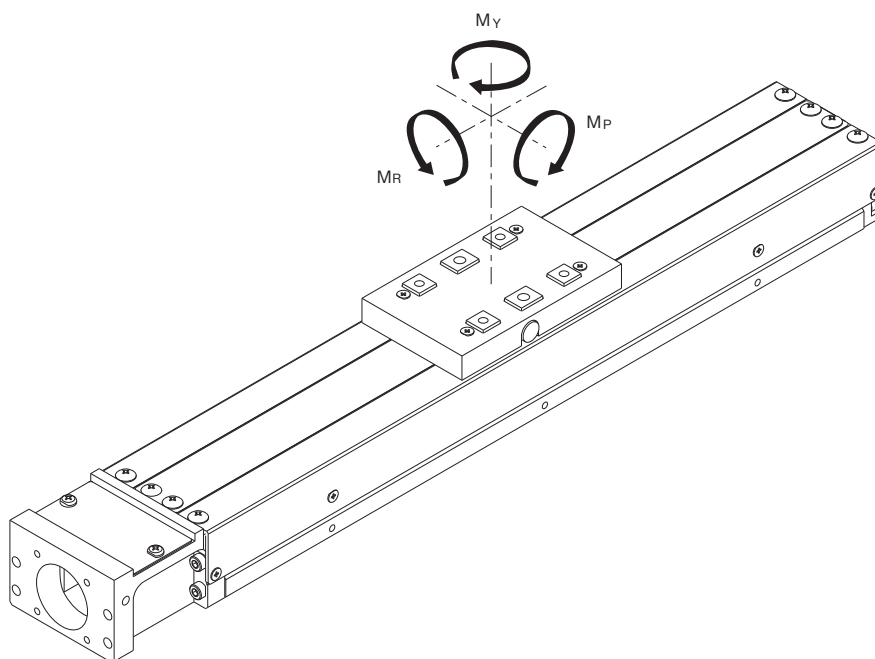

ACCURACY

Model No.	Guide rail length (mm)	Repeated positioning accuracy (μm)			Positioning accuracy (μm)			Travelling parallelism B (μm)			Backlash (μm)			Starting torque (Note 2) ($\text{N}\cdot\text{m}$)		
		W	U	H	W	U	H	W	U	H	W	U	H	W	U	H
SC23	150	± 10	± 5	± 3	70			15	15	20	5	5	0.03	0.06	0.06	
	200				75											
	250				85											
	300				90											
SC30	150	± 10	± 5	± 3 (± 5)	70			15	15	20	5	5	0.07	0.15	0.15	
	200				80											
	300				90											
	400				95											
	500				100											
	600			110			100	25	25							
	700			120			25									-
	750			130				-	-							
SC45	540	± 10	± 5	± 3 (± 5)	110			40	40	20	5	5	0.1	0.2	0.2	
	640				120											
	740				130			120								
	840				150			150	50							50
	940				170											

(Note 1) Measurement is to be performed with KURODA's specified motor mounted.

(Note 2) Above starting torque value is applied when the standard grease is used. The value may change depending on the properties of the grease.

(Note 3) For repeated positioning accuracy, the value in parentheses is for parallel motor mounted configurations.

INERTIA

Inertia for slide block and ball screw of ballscrew actuator is shown in the following table.

(Unit : $\times 10^{-5} \text{kg}\cdot\text{m}^2$)

Model No.	Guide rail length (mm)	Full-cover type	
		Long block	
		A: 1 block	
SC2302	150	0.0616	
	200	0.0773	
	250	0.0930	
	300	0.1090	
SC2305	150	0.0756	
	200	0.0913	
	250	0.1070	
	300	0.1230	
SC3004	150	0.165	
	200	0.204	
	300	0.280	
	400	0.357	
	500	0.434	
	600	0.510	
	700	0.587	
SC3005	150	0.176	
	200	0.214	
	300	0.291	
	400	0.367	
	500	0.444	
	600	0.521	
	700	0.597	
SC3006	150	0.188	
	200	0.227	
	300	0.303	
	400	0.380	
	500	0.457	
	600	0.533	
	700	0.610	
SC3010	150	0.261	
	200	0.299	
	300	0.376	
	400	0.453	
	500	0.529	
	600	0.606	
	700	0.683	
SC3020	150	0.602	
	200	0.640	
	300	0.717	
	400	0.793	
	500	0.870	
	600	0.947	
	700	1.023	
SC4505	540	2.43	
	640	2.81	
	740	3.20	
	840	3.59	
	940	3.98	
SC4510	540	2.68	
	640	3.07	
	740	3.46	
	840	3.84	
	940	4.23	
SC4520	540	3.69	
	640	4.08	
	740	4.47	
	840	4.86	
	940	5.24	

SG
SG20
SG26
SG33
SG46
SG55

SE
SE15
SE23
SE30
SE45

SC
SC23
SC30
SC45

Sensor

Technical Data

SC23

● FULL-COVER TYPE LONG BLOCK CONFIGURATIONS

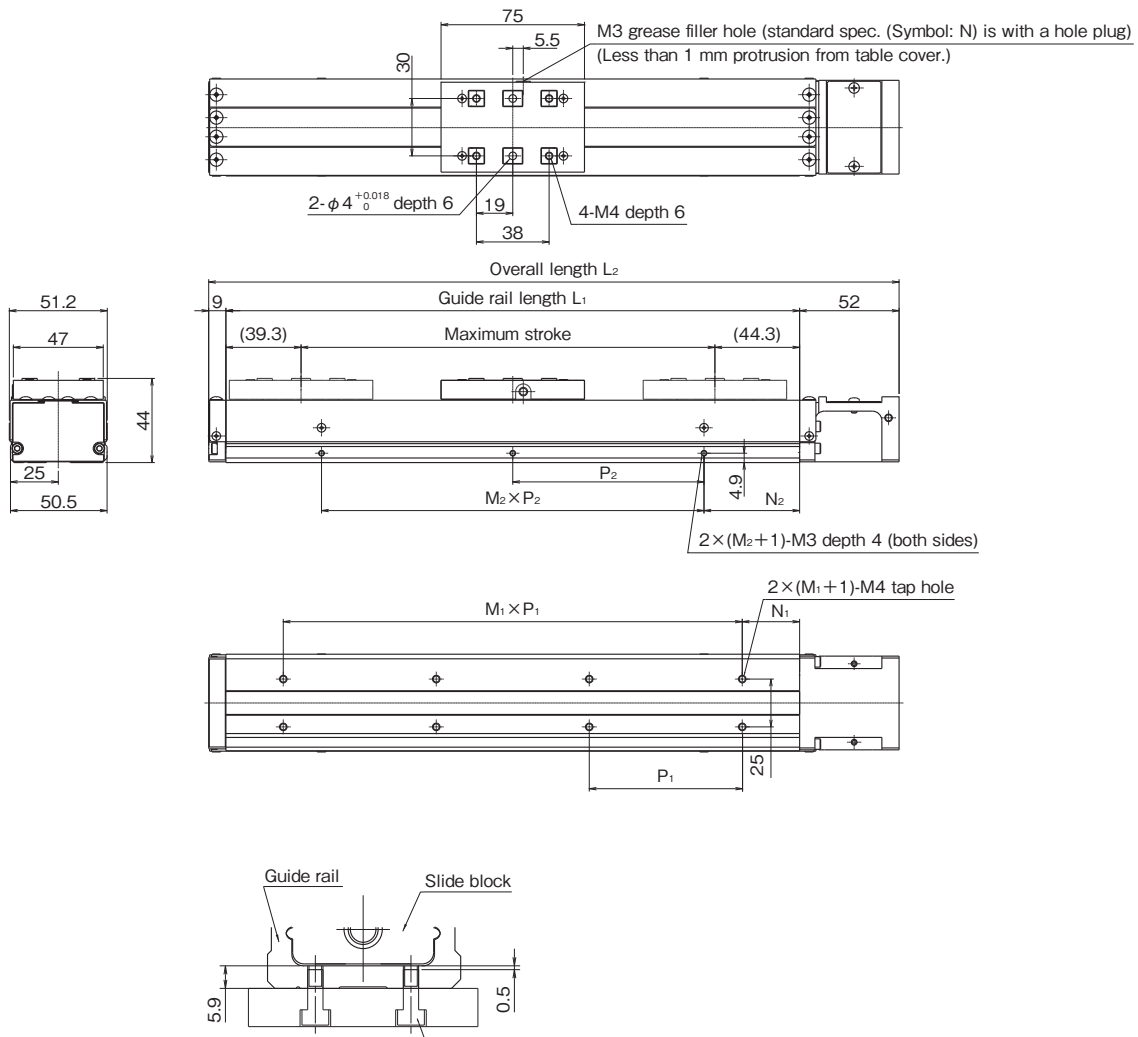

SC23

● FULL-COVER TYPE LONG BLOCK DIMENSIONS

(Unit: mm)

Guide rail length L_1	Overall length L_2	N_1	$M_1 \times P_1$	N_2	$M_2 \times P_2$	Maximum stroke	
						Long block	Long block (with LUBSEAL)
						A: 1 block	E: 1 block
150	211	35	1 × 80	25	1 × 100	66	—
200	261	20	2 × 80	50		116	110
250	311	45		3 × 80	25	2 × 100	166
300	361	30	50		216		210

● PERMISSIBLE SPEED / MASS

Guide rail length L_1 (mm)	Permissible speed (mm/s)		Mass (kg)	
	Lead		Full-cover type	Mass of table (slide block + table + table cover parts)
	2mm	5mm	A: With 1 long block	
150	200	490	1.20	0.25
200			1.41	
250			1.63	
300			1.84	

(Note 1) Mass of full-cover type actuators in the above table includes mass of table.

(Note 2) For long rail configurations, please consult KURODA.

● MOTOR BRACKET CONFIGURATIONS

Please refer to Pages 68 to 71 of SE23 series regarding to motor bracket configurations.

● DOWEL PIN HOLE (Guide rail only)

Please refer to Pages 73 of SE23 series regarding to guide rail positioning hole.

SC23

● FULL-COVER TYPE SUB GUIDE RAIL CONFIGURATIONS

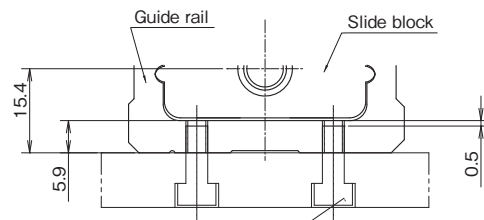
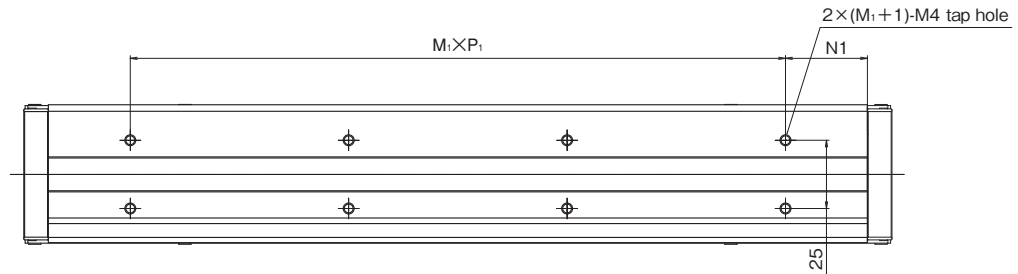
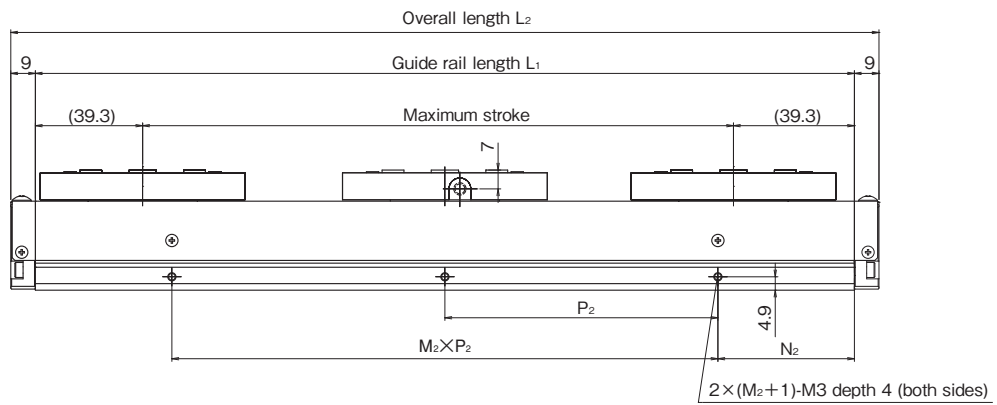
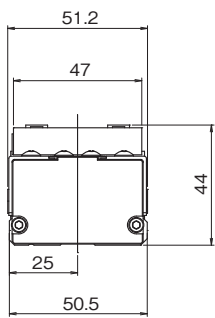
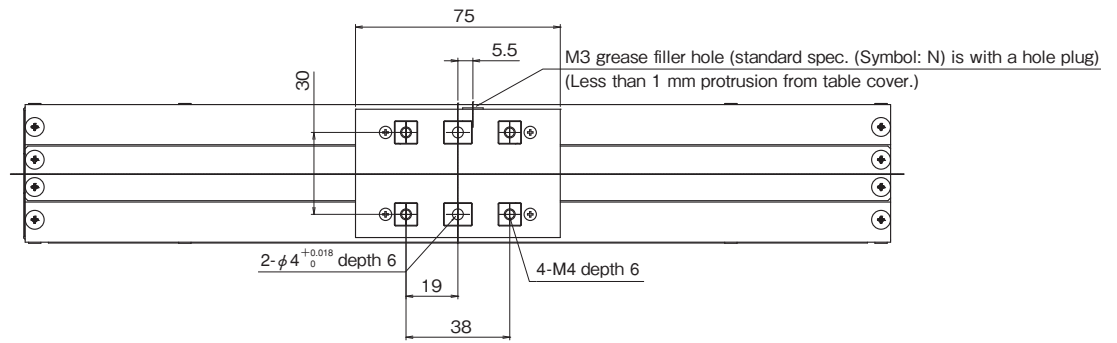

Length of fixing bolts should be determined to the length that satisfies above-mentioned conditions.
(Fixing bolts longer than thickness of bottom surface of guide may interfere with function of slide block.)

SC23

● FULL-COVER TYPE SUB GUIDE RAIL DIMENSIONS

(Unit: mm)

Guide rail length L_1	Overall length L_2	N_1	$M_1 \times P_1$	N_2	$M_2 \times P_2$	Maximum stroke	
						Long block	Long block (with LUBSEAL)
						A: 1 block	E: 1 block
150	211	35	1 × 80	25	1 × 100	71	—
200	261	20	2 × 80	50		121	115
250	311	45		3 × 80	25	2 × 100	171
300	361	30	50		221		215

● PERMISSIBLE SPEED / MASS

Guide rail length L_1 (mm)	Permissible speed (mm/s)	Mass (kg)	
		Full-cover type	Mass of table (slide block + table + table cover parts)
	Lead	A: With 1 long block	
150	490	1.12	0.25
200		1.32	
250		1.51	
300		1.71	

(Note 1) Mass of full-cover type actuators in the above table includes mass of table.

(Note 2) For long rail configurations, please consult KURODA.

SG

SG20

SG26

SG33

SG46

SG55

SE

SE15

SE23

SE30

SE45

SC

SC23

SC30

SC45

Sensor

Technical Data

SC23

● COVER CONFIGURATION

The below-mentioned configurations with grease nipple and/or wiper are available for full-covered series. Standard specification (Symbol: N) has a plug equipped with grease filler hole.

Full-cover type with grease nipple (Symbol: G)

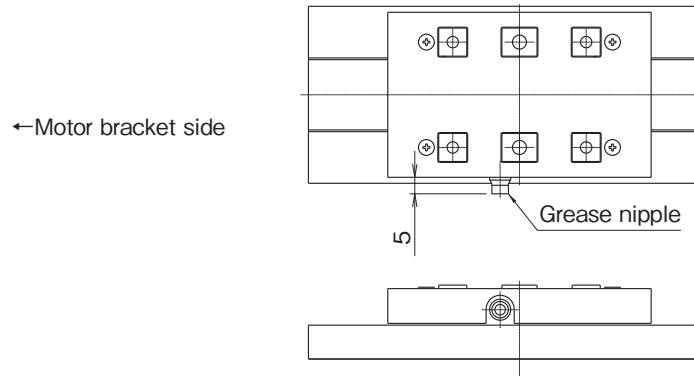

Full-cover type with wiper (Symbol: S)

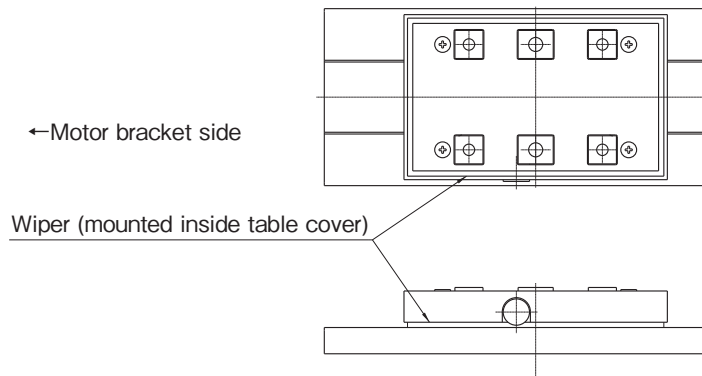

Full-cover type with grease nipple and wiper (Symbol: D)

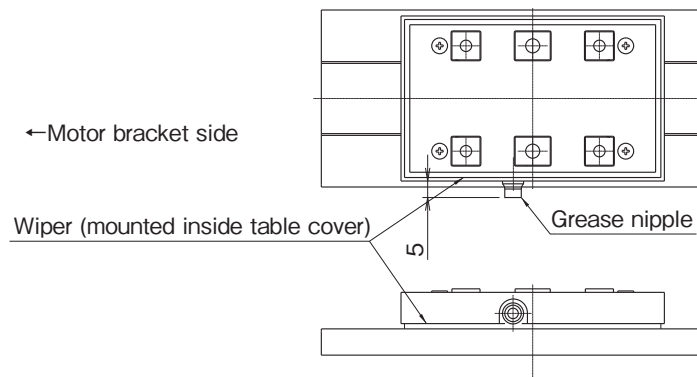

SC23

● SENSOR

Symbol S (NPN): Photo-microsensor (Panasonic Industrial Devices SUNX)

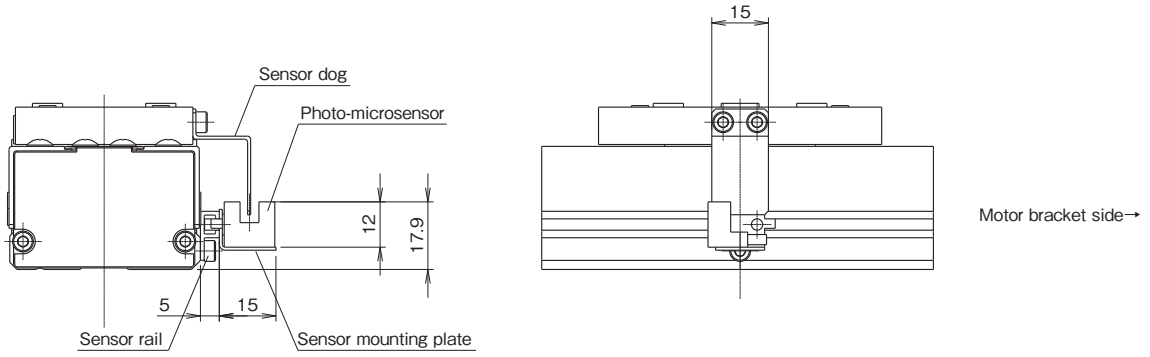

Symbol K (NPN) / E (PNP): Proximity sensor (Azbil)

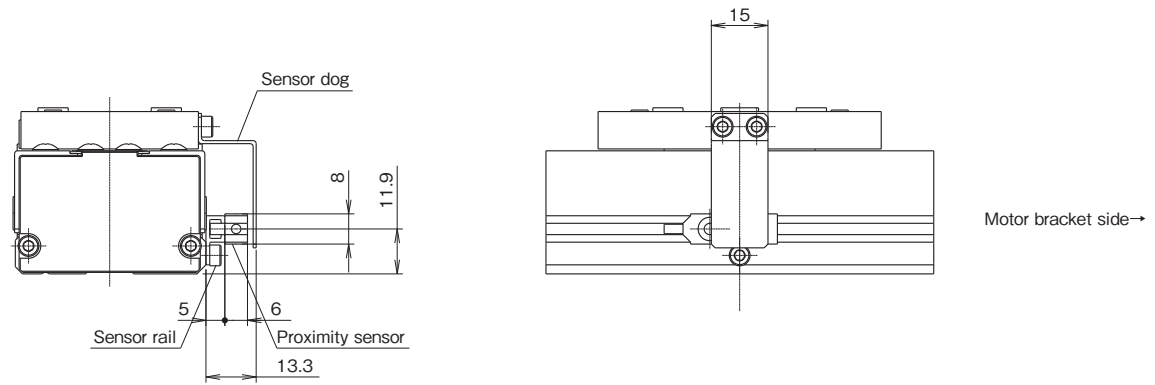

● SENSOR RAIL

Sensor rails only available with no sensors.

Sensor rail No. 1

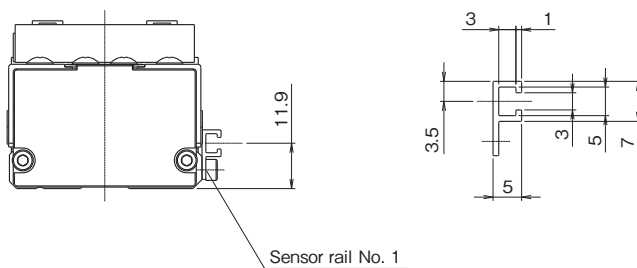

SG
SG20
SG26
SG33
SG46
SG55
SE
SE15
SE23
SE30
SE45
SC
SC23
SC30
SC45
Sensor
Technical Data

SC30

● FULL-COVER TYPE LONG BLOCK CONFIGURATIONS

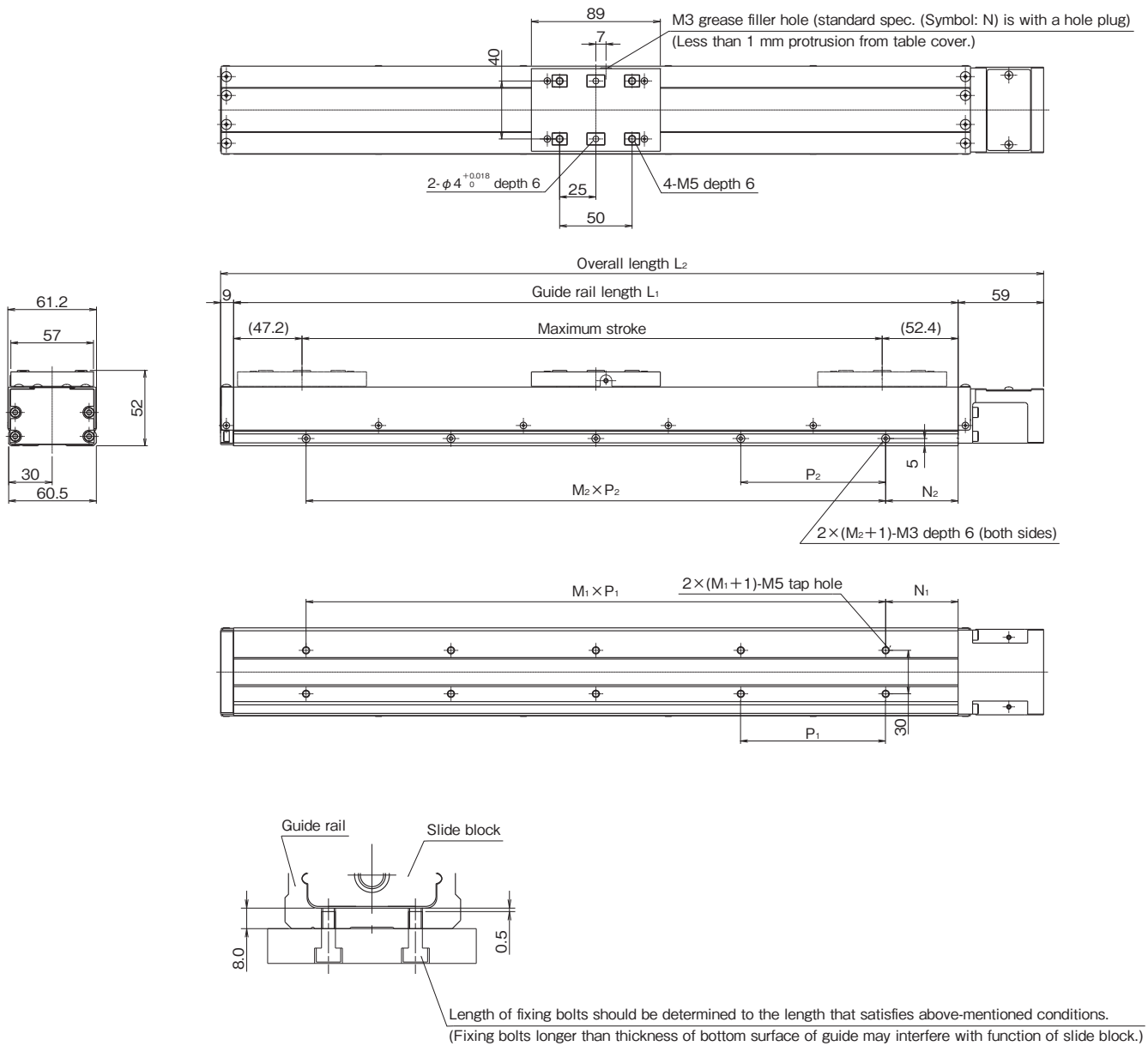

SC30

● FULL-COVER TYPE LONG BLOCK DIMENSIONS

(Unit: mm)

Guide rail length L_1	Overall length L_2	N_1	$M_1 \times P_1$	N_2	$M_2 \times P_2$	Maximum stroke	
						Long block	Long block (with LUBSEAL)
						A: 1 block	E: 1 block
150	218	25	1 × 100	25	1 × 100	50	—
200	268	50		50		100	94
300	368		2 × 100		200	194	
400	468		3 × 100		300	294	
500	568		4 × 100		400	394	
600	668		5 × 100		500	494	
700	768	6 × 100	600	594			
750	818	25	7 × 100	25	7 × 100	650	644

● PERMISSIBLE SPEED / MASS

Guide rail length L_1 (mm)	Permissible speed (mm/s)					Mass (kg)	
	Lead					Full-cover type	Mass of table (slide block + table + table cover parts)
	4mm	5mm	6mm	10mm	20mm	A: With 1 long block	
150	320	400	480	810	1200	1.9	0.43
200						2.2	
300						2.9	
400						3.5	
500						4.2	
600	240	300	360	600	4.9		
700	170	210	250	430	910	5.5	
750	—	—	—	380	790	5.8	

(Note 1) Guide rail length of 750 mm is available only for SC3010.

(Note 2) Mass of full-cover type actuators in the above table includes mass of table.

(Note 3) For long rail configurations, please consult KURODA.

● MOTOR BRACKET CONFIGURATIONS

Please refer to Pages 78 to 81 of SE30 series regarding to motor bracket configurations and parallel motor mounting.

● DOWEL PIN HOLE (Guide rail only)

Please refer to Pages 83 of SE30 series regarding to guide rail positioning hole.

SC30

● FULL-COVER TYPE SUB GUIDE RAIL CONFIGURATIONS

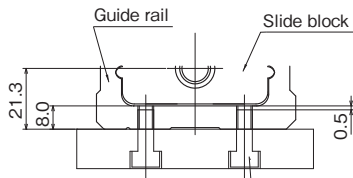
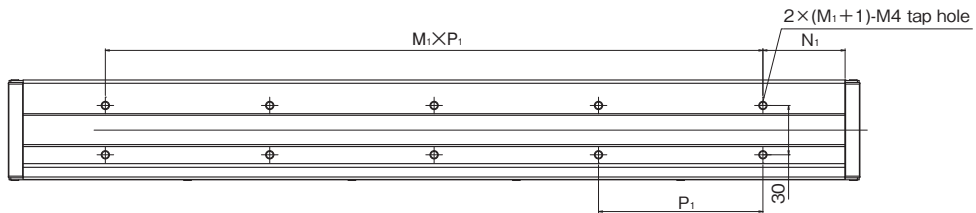
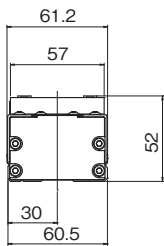
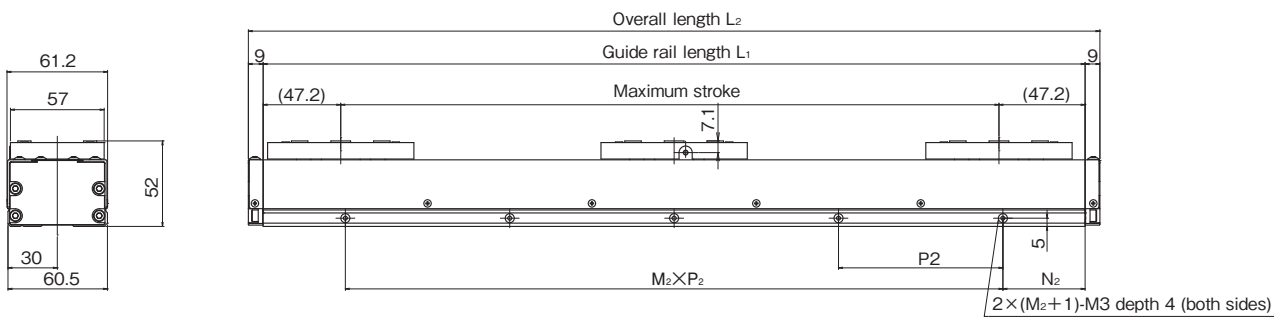
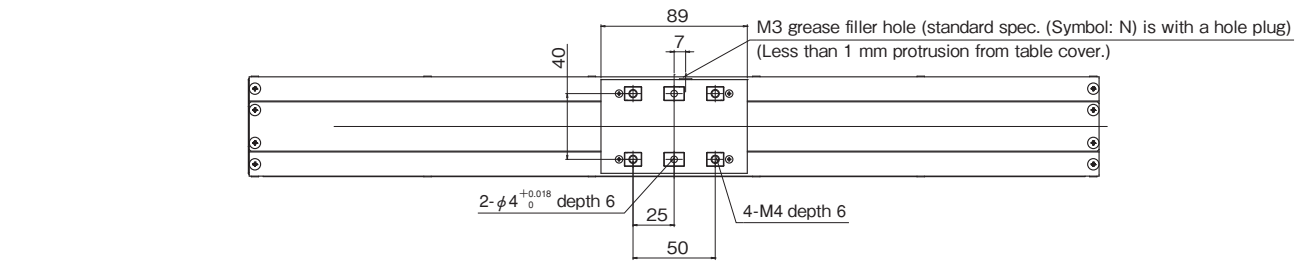

Length of fixing bolts should be determined to the length that satisfies above-mentioned conditions.
(Fixing bolts longer than thickness of bottom surface of guide may interfere with function of slide block.)

SC30

● FULL-COVER TYPE SUB GUIDE RAIL DIMENSIONS

(Unit: mm)

Guide rail length L_1	Overall length L_2	N_1	$M_1 \times P_1$	N_2	$M_2 \times P_2$	Maximum stroke	
						Long block	Long block (with LUBSEAL)
						A: 1 block	E: 1 block
150	218	25	1 × 100	25	1 × 100	55	—
200	268	50		50		105	99
300	368		2 × 100		205	199	
400	468		3 × 100		305	299	
500	568		4 × 100		405	399	
600	668		5 × 100		505	499	
700	768	6 × 100	605	599			
750	818	25	7 × 100	25	7 × 100	655	649

● PERMISSIBLE SPEED / MASS

Guide rail length L_1 (mm)	Permissible speed (mm/s)	Mass (kg)	
		Full-cover type	Mass of table (slide block + table + table cover parts)
	Lead	A: With 1 long block	
150	1200	1.80	0.43
200		2.09	
300		2.69	
400		3.28	
500		3.87	
600		4.46	
700		5.05	
750		5.35	

(Note 1) Guide rail length of 750 mm is available only for SC3010.

(Note 2) Mass of full-cover type actuators in the above table includes mass of table.

(Note 3) For long rail configurations, please consult KURODA.

SC30

● COVER CONFIGURATION

The below-mentioned configurations with grease nipple and/or wiper are available for full-covered series. Standard specification (Symbol: N) has a plug equipped with grease filler hole.

Full-cover type with grease nipple (Symbol: G)

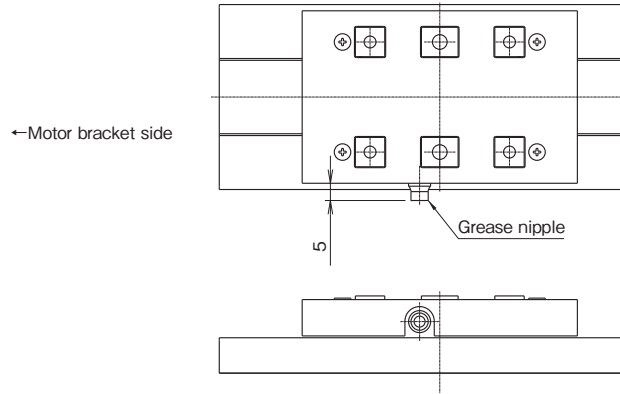

Full-cover type with wiper (Symbol: S)

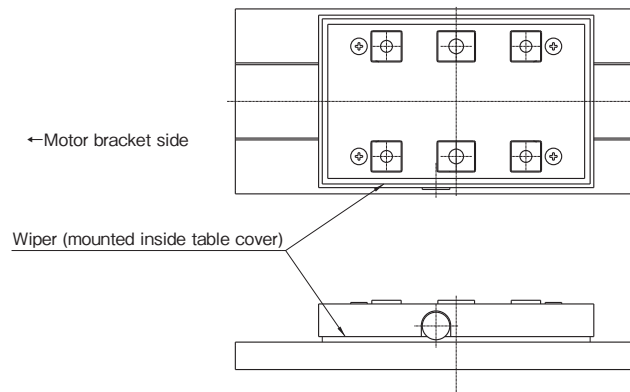

Full-cover type with grease nipple and wiper (Symbol: D)

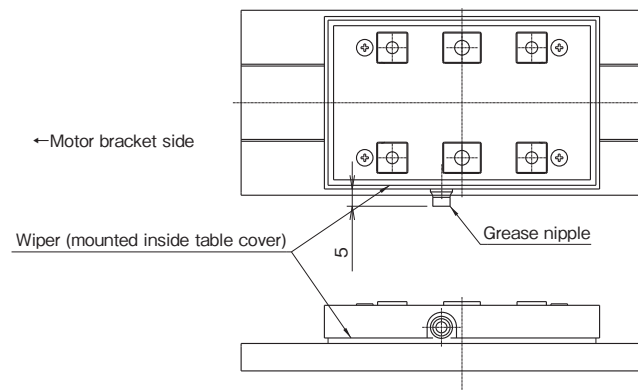

SC30

● SENSOR

Symbol C (NPN) / P (PNP), M (NPN) / Y (PNP): Photo-microsensor (OMRON, Panasonic Industrial Devices SUNX)

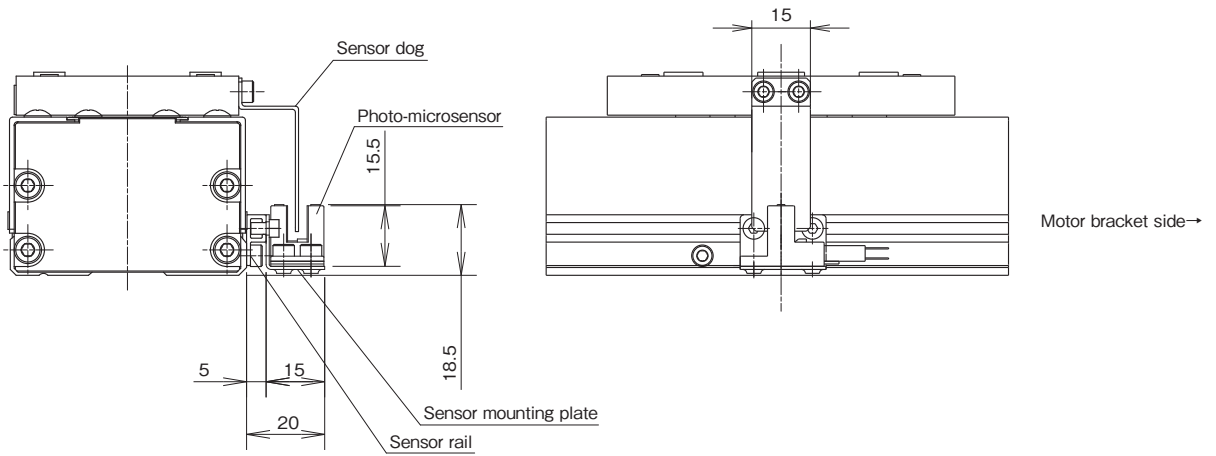

Symbol K (NPN) / E (PNP): Proximity sensor (Azbil)

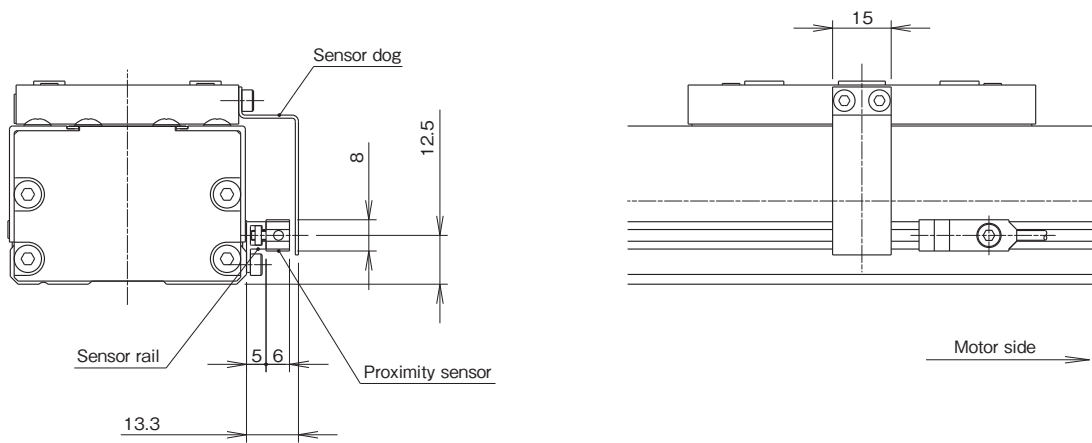

● SENSOR RAIL

Sensor rails only available with no sensors.

Sensor rail No. 1

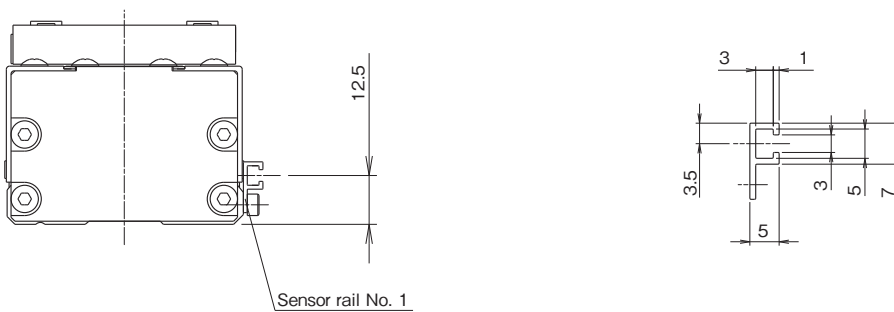

SC45

● FULL-COVER TYPE LONG BLOCK CONFIGURATIONS

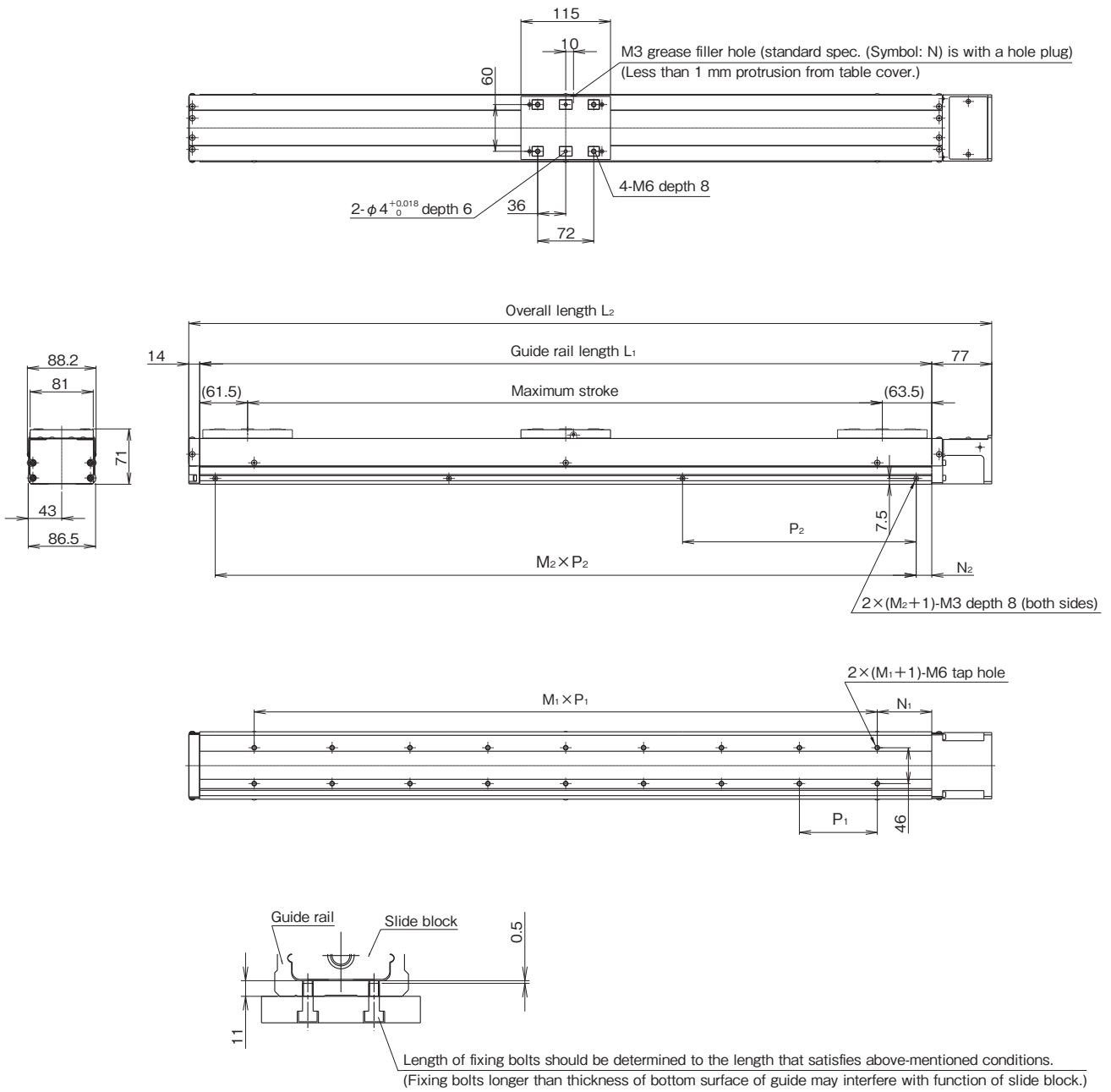

SC45

● FULL-COVER TYPE LONG BLOCK DIMENSIONS

(Unit: mm)

Guide rail length L_1	Overall length L_2	N_1	$M_1 \times P_1$	N_2	$M_2 \times P_2$	Maximum stroke	
						Long block	Long block (with LUBSEAL)
						A: 1 block	E: 1 block
540	631	70	4×100	20	2×250	415	407
640	731		5×100		2×300	515	507
740	831		6×100		2×350	615	607
840	931		7×100		2×400	715	707
940	1031		8×100		3×300	815	807

● PERMISSIBLE SPEED / MASS

Guide rail length L_1 (mm)	Permissible speed (mm/s)			Mass (kg)	
	Lead			Full-cover type	Mass of table (slide block + table + table cover parts)
	5mm	10mm	20mm	A: With 1 long block	
540	260	520	1040	9.2	1.27
640				10.5	
740				11.8	
840				13.0	
940	200	410	830	14.3	

(Note 1) Mass of full-cover type actuators in the above table includes mass of table.

(Note 2) For long rail configurations, please consult KURODA.

● MOTOR BRACKET CONFIGURATIONS

Please refer to Pages 92 to 95 of SE45 series regarding to motor bracket configurations and parallel motor mounting.

● DOWEL PIN HOLE (Guide rail only)

Please refer to Pages 97 of SE45 series regarding to guide rail positioning hole.

SC45

● FULL-COVER TYPE SUB GUIDE RAIL CONFIGURATIONS

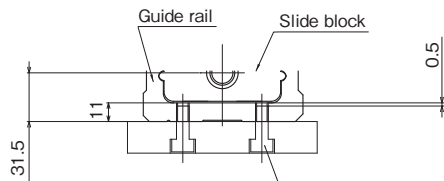
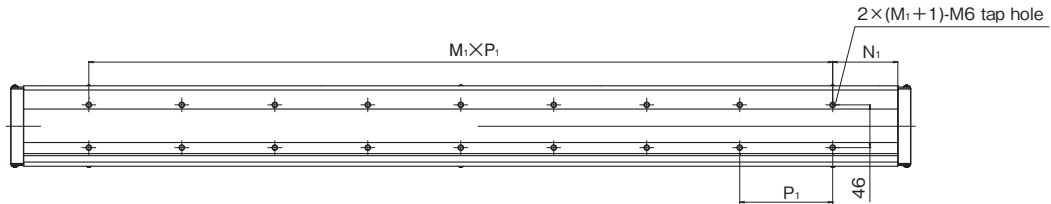
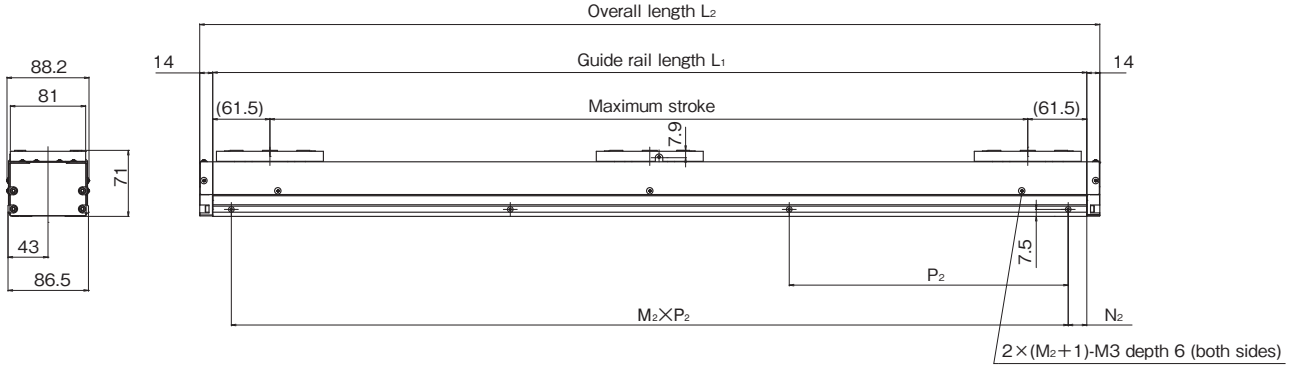
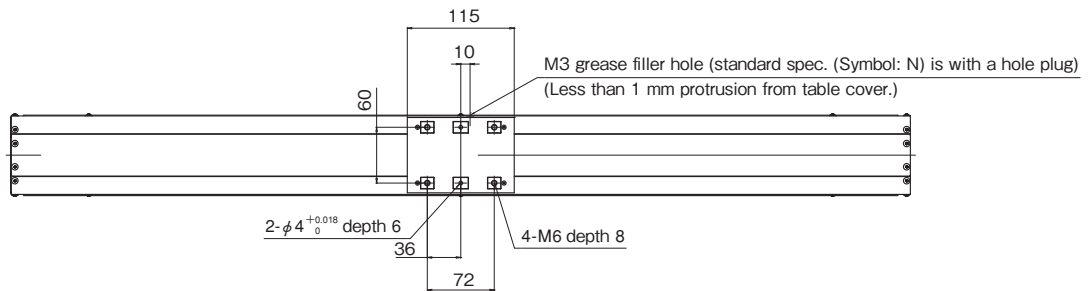

Length of fixing bolts should be determined to the length that satisfies above-mentioned conditions.
(Fixing bolts longer than thickness of bottom surface of guide may interfere with function of slide block.)

SC45

● FULL-COVER TYPE SUB GUIDE RAIL DIMENSIONS

(Unit: mm)

Guide rail length L_1	Overall length L_2	N_1	$M_1 \times P_1$	N_2	$M_2 \times P_2$	Maximum stroke	
						Long block	Long block (with LUBSEAL)
						A: 1 block	E: 1 block
540	631	70	4×100	20	2×250	417	409
640	731		5×100		2×300	517	509
740	831		6×100		2×350	617	609
840	931		7×100		2×400	717	709
940	1031		8×100		3×300	817	809

● PERMISSIBLE SPEED / MASS

Guide rail length L_1 (mm)	Permissible speed (mm/s)	Mass (kg)	
		Full-cover type	Mass of table (slide block + table + table cover parts)
	Lead	A: With 1 long block	
540	2000	8.5	1.27
640		9.7	
740		10.8	
840		12.0	
940		13.1	

(Note 1) Mass of full-cover type actuators in the above table includes mass of table.

(Note 2) For long rail configurations, please consult KURODA.

SG

SG20

SG26

SG33

SG46

SG55

SE

SE15

SE23

SE30

SE45

SC

SC23

SC30

SC45

Sensor

Technical Data

SC45

● COVER CONFIGURATION

The below-mentioned configurations with grease nipple and/or wiper are available for full-covered series. Standard specification (Symbol: N) has a plug equipped with grease filler hole.

Full-cover type with grease nipple (Symbol: G)

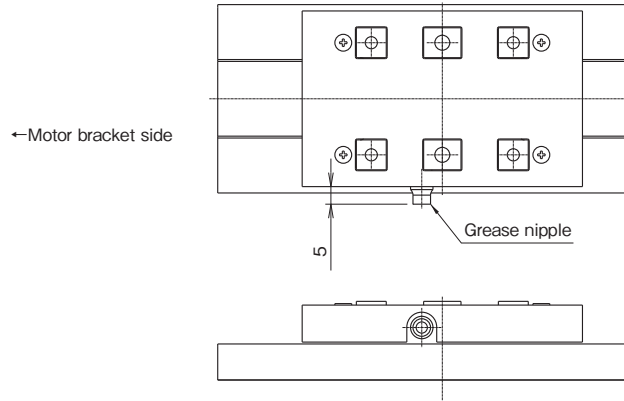

Full-cover type with wiper (Symbol: S)

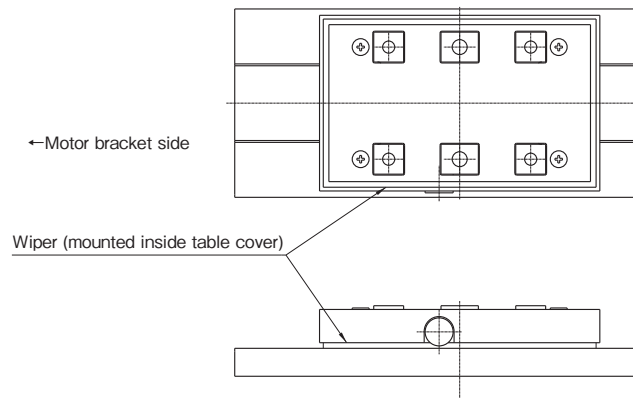

Full-cover type with grease nipple and wiper (Symbol: D)

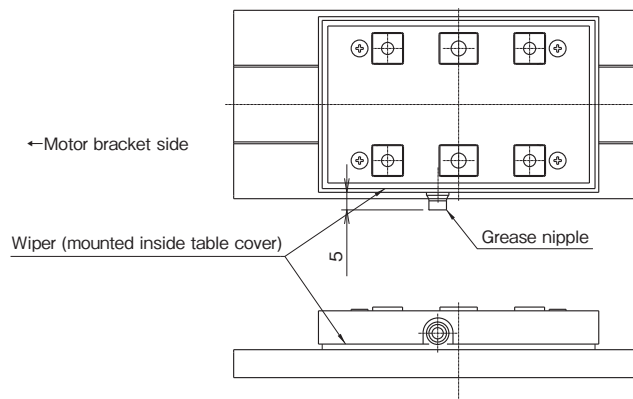

SC45

● SENSOR

Symbol C (NPN) / P (PNP), M (NPN) / Y (PNP): Photo-microsensor (OMRON, Panasonic Industrial Devices SUNX)

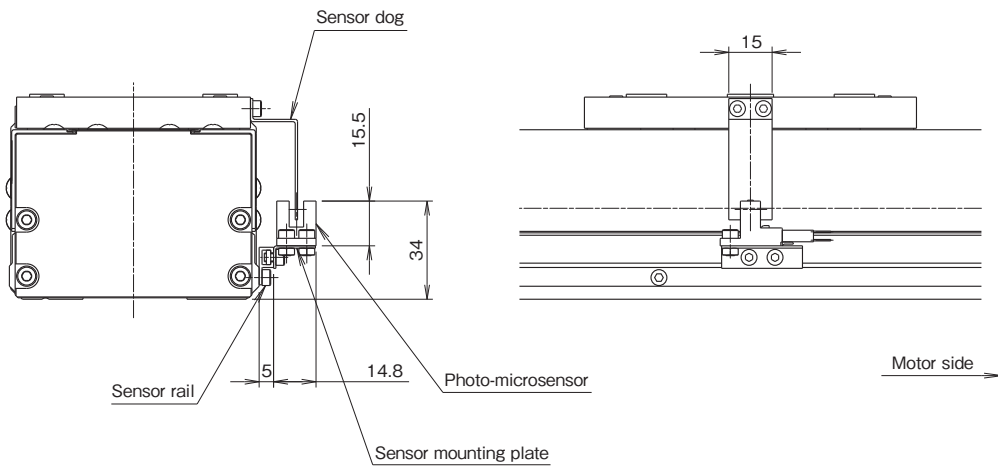

Symbol K (NPN) / E (PNP): Proximity sensor (Azbil)

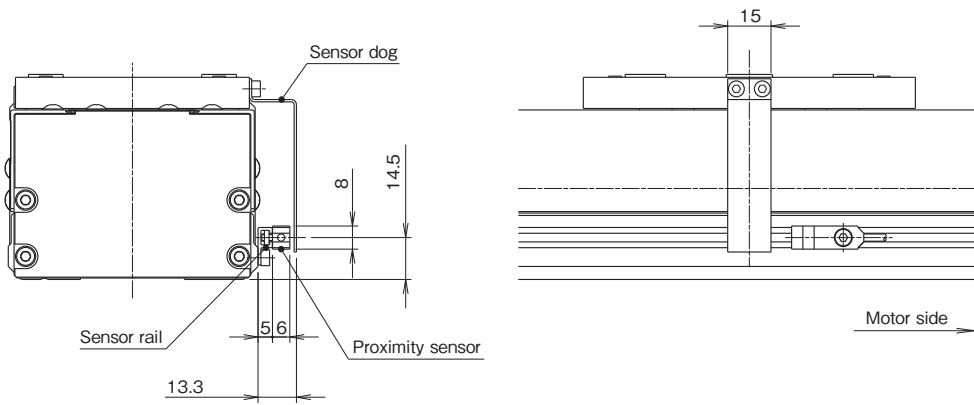

● SENSOR RAIL

Sensor rails only available with no sensors.

Sensor rail No. 1

