

J-Series: JTs7 Metric Rolled

Rolled Screw, C7 Accuracy

Shaft Diameters
Standard 16-63mm

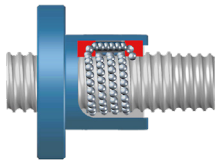
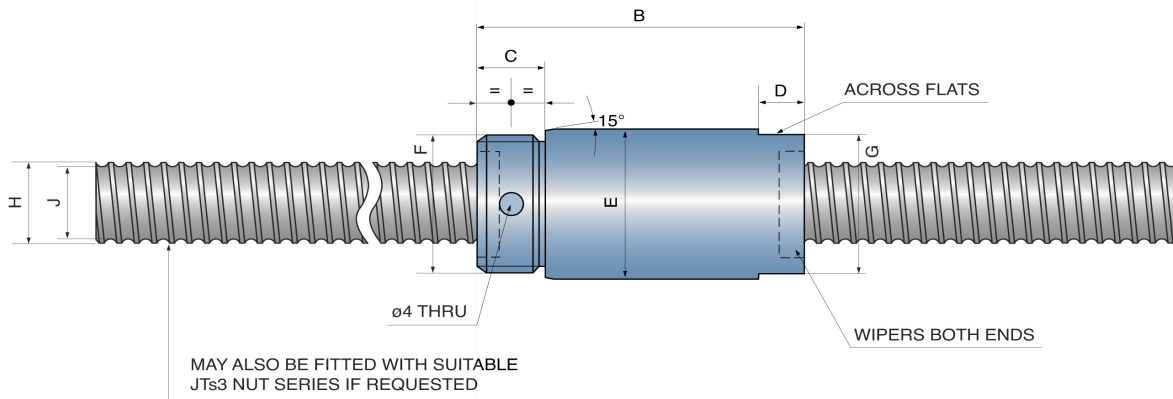

*Nut A: Single Nut Recirculating

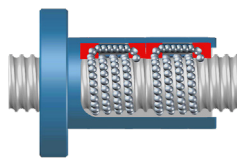

*Nut B: PitchShift

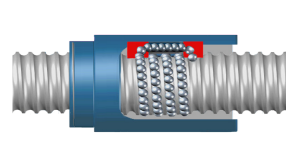

Nut C: Nose Thread

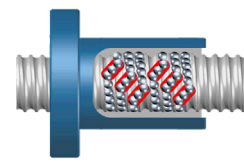

*Nut D: Single Nut Insert Transfer

SHAFT DIAM Ø H (mm)	LEAD (mm)	Series	Accuracy Grade	NUT STYLE	Max SCREW OAL (mm)	Max Nut OAL mm B	C (mm)	D (mm)	NUT BODY DIAM Ø (mm)	F	G	Minor DIAM Ø (mm)	J (mm)	# TURNS	AXIAL PLAY max	LOAD RATING	
																DYN daN	STATIC daN
16	05	JTs7	7	C or A*	3600	44	12	8	30	M26x1,5	28	15	12.90	3	0.05	840	1290
16	05	JTs7-LH	7	C	3600	44	12	8	30	M26x1,5	28	15	12.90	3	0.05	840	1290
16	10	JTs7	7	C or A*	3000	47	12	8	30	M26x1,5	28	15	12.90	2	0.05	600	900
20	05	JTs7	7	C or A*	3500	52	14	8	40	M35x1,5	36	19	16.40	4	0.06	1520	2650
25	05	JTs7	7	C or A*	3600	57	19	8	45	M40x1,5	40	24	21.40	4	0.06	1680	3290
25	05	JTs7-LH	7	C	3600	57	19	8	45	M40x1,5	40	24	21.40	4	0.06	1680	3290
25	10	JTs7	7	C or A*	3600	79	19	8	45	M40x1,5	40	24	21.40	4	0.06	2300	4100
32	05	JTs7	7	C or B*	3600	57	19	8	55	M48x1,5	50	31	28.40	4	0.06	1870	4250
32	05	JTs7-LH	7	C	3700	57	19	8	55	M48x1,5	50	31	28.40	4	0.06	1870	4250
32	10	JTs7	7	C or B*	3600	85	19	8	60	M55x1,5	56	30	25.10	4	0.08	3740	6880
40	05	JTs7	7	C or B*	3600	56	19	10	60	M55x1,5	56	39	36.40	4	0.06	2050	5340
40	10	JTs7	7	C or B*	3600	90	24	10	65	M60x1,5	60	38	33.80	4	0.08	4340	9180
40	20	JTs7	7	C or B*	3600	86	24	10	65	M60x1,5	60	38	33.80	4	0.08	4280	9090
50	05	JTs7	7	C or B*	3600	76	30	12	77	M72x1,5	72	48	42.60	5	0.10	5790	14400
50	10	JTs7	7	C, *B, *D	3600	110	30	12	77	M72x1,5	72	48	42.60	5	0.10	5790	14400
50	12	JTs7	7	C or B*	3600	132	30	12	85	M72x1,5	80	48	40.60	6	0.10	8600	20500
63	10	JTs7	7	C, *B, *D	3600	110	30	12	90	M85x2	84	61	55.60	5	0.10	8050	21300
63	12	JTs7	7	C, *B, *D	3600	133	30	12	95	M85x2	90	61	53.70	6	0.10	9390	25500

*A, *B, *D - Interchangeable Ball Nut for all Screw Accuracies

*Refer to JTs3 Specifications for Nut dimensions

LH refers to LEFT-HAND leads

Ordering Example

Series	Accuracy Grade	Screw Shaft Dia (mm) 2-digit #	Shaft Lead (mm) 2 or 3 digit #	Thread Direction R=Right-hand (Standard) L=Left-hand	Overall Screw Shaft Length (mm)	Thread Length (mm)	S=Shaft only N=Nut only A= Assembly (shaft and nut)	Nut Style (A, B, C, D, E, F)	"SPL" Special with Options (different from Catalog)
JTs	7	20	05	R	3600	3300	A	C	
1	2	3	4	5	6	7	8	9	10