

F-Series: Ultra-Quiet End-Deflector Method

Applications: Semiconductor, SMT, Machine Tool, Medical Lab

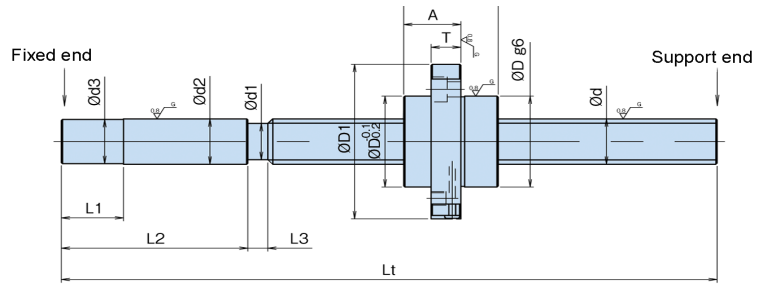
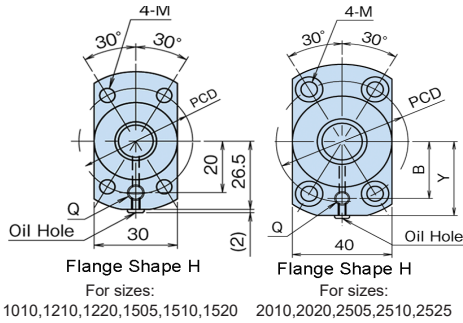

Ordering Example: F-Series

Series	Screw Shaft Dia	Shaft Lead	# of Circuits	Nut Type	Flange Type	Ball Return System	Wiper Material	Thread Direction	Overall Screw Shaft Length	Shaft End Type	Thread Length	Accuracy Grade	Axial Clearance
FE	15	10	P	S	H	P	N	R	1500	X	1440	C5	M
①	②	③	④	⑤	⑥	⑦	⑧	⑨	⑩	⑪	⑫	⑬	⑭

Shaft Dimensions: FG(Unmachined Ends, Ground C5) / FE (Ground C7) / FK (Whirled C5)

Model No.	Shaft diameter d	Lead	Root diameter d1	Circuit & turn	Axial clearance	Basic dynamic load rating (N)	Basic static load rating (N)	Shaft dimensions					Overall Screw Shaft Length Lt (mm)
								Shaft ends					
								d2	d3	L1	L2	L3	
FG / FE 1010PS-HPNR	10	10	8.1	1.7×1	M: FE F: FG	2600	3800	14	13.7	20	55	8	255/455
FG / FE / FK 1210PS-HPNR	12	10	9.5	2.7×1		6700	10700	12	11.7			5	455/605
FG / FE / FK 1220PS-HPNR		20	9.5	1.7×1		4300	6700	12		455/605			
FG / FE / FK 1505PS-HPNR	15	5	12.5	2.7×1		7400	12900	15	14.5	25	55	5	600/1100
FG / FE / FK 1510PS-HPNR		10	12.5	2.7×1		7400	12900						600/900/1100
FG / FE / FK 1520PS-HPNR		20	12.5	1.7×1		4800	8200						600/900/1100
FG / FE / FK 2010PS-HPNR	20	10	16	2.7×1		18000	33900	20	19.5	75	8	605/1005/1505	
FG / FE / FK 2020PS-HPNR		20	15.9	1.7×1		11600	20600					1005/1505	
FG / FE / FK 2505PS-HPNR	25	5	22.5	3.7×1		13100	31800	25	24.5	100	5	600/1000/1505	
FG / FE / FK 2510PS-HPNR		10	21	2.7×1		20400	42600					1020/1520	
FG / FE / FK 2525PS-HPNR		25	1.7×1	13100	25900	1020/1520							

Axial clearance M: Max 0.030mm, F:Max 0.005mm Wiper Material N: No wiper or S: Lubseal Option

Nut Dimensions: FG(Unmachined Ends, Ground C5) / FE (Ground C7) / FK (Whirled C5)

Model No.	Nut dimensions													
	Body diameter D	Lt	A	Flange							Mounting hole M	Mounting hole M Counter bore hole	Mounting hole M Counter bore depth	Oil hole Q
				T	D1	X	Y	PCD P	B					
FG / FE 1010PS-HPNR	23	27	17.5	10	44	24	21.5	32	16	4.5	-	-	M3	
FG / FE / FK 1210PS-HPNR	27	38	19.5	10	47	27	23	36	18	4.5				
FG / FE / FK 1220PS-HPNR	27	48	20	10	47	27	23	36	18	4.5				
FG / FE / FK 1505PS-HPNR	30	25	17.3	9.5	54	30	26.5	41	20	5.5	-	-	M6	
FG / FE / FK 1510PS-HPNR	30	38	20	10	54	30	26.5	41	20					
FG / FE / FK 1520PS-HPNR	30	48	20.5	10	54	30	26.5	41	20					
FG / FE / FK 2010PS-HPNR	40	38	23	12	68	40	32.5	53	25	6.6	11	6.5	M6	
FG / FE / FK 2020PS-HPNR		48	23	12										
FG / FE / FK 2505PS-HPNR	40	30	20	12	68	40	32.5	53	25					
FG / FE / FK 2510PS-HPNR	45	37	25	15	74	45	35.5	59	28					
FG / FE / FK 2525PS-HPNR		58	27	15										