

Standard precision ball screws

Features

● GP, GG, GE series: Various screw shaft diameters, leads, and accuracy grades available for your selection

- An optimal size can be selected from a variety of screw shaft diameters, leads, and accuracy grades eliminating unnecessary compromise in product selection.

● FG, FE series: High rotational speed

- Delivers higher rotational speed up to 5,000 min⁻¹ through our unique recirculation system.
- In consideration of the load rating, the products have higher specifications than previous KURODA products.

● DP series: The industry's smallest compact nut class

- Utilizes a deflector recirculation system which realizes minimal nut dimensions.
- With leads from 1 mm, the DP series is suitable for machines and equipment that requires fine pitch forwarding and precise positioning.

● HG series: Optimal for high-speed conveyance achieved by larger leads

- Larger leads enable a higher feed rate at a low rotational speed.
- With the adoption of multi-start thread, we have achieved a more compact nut with an improved load rating.

□ Summary of the specifications

Screw shaft diameter	ø6 to ø32 mm
Lead	1 to 60 mm
Accuracy grade	C3 grade: GP, DP C5 grade: FG, GG, HG C7 grade: FE, GE
Axial clearance	Refer to each product specification table.
Shaft end type	One shaft end finished (C3 grade: GP, DP) Unfinished shaft ends
Product line	Standard product

□ Options available

Series	Additional shaft-end machining	Surface treatment	Change of grease type	Change of nut direction	LUBSEAL
GP, DP FG, GG, HG FE, GE	○	○	○	○	See the notes below.

- The GP and DP series have one shaft end finished.
- The surface treatment is anticorrosive black coating (coating thickness: 1 to 2 μm).
- Contact KURODA regarding the inclusion of grease types other than the standard grease.
- Please refer to the LUBSEAL series and size reference chart or the option specifications on each product's page to determine whether or not LUBSEAL is supported.

□ Model numbers of each series

Example model numbers	Series	Shaft diameter	Lead	Number of circuits	Combination	Flange type	Ball recirculation system	Wiper material	Thread direction	Overall screw shaft length	Shaft end type	Thread length	Accuracy grade	Axial clearance
	FG	15	10	P	S	H	P	N	R	0900	X	0840	C5	F
DP	6 to 14	1 to 4	J	S	H	D	N	R	To be shown with a 4-digit number in metric units (mm)	B, X	To be shown with a 4-digit number in metric units (mm)	C3	F, S	
FG	10 to 25	5 to 25	P		H	P	N					C5	F	
FE					See specifications.	A	See specifications.					C7	M	
GG	8 to 32	2 to 25	Q									C5	F	
GE	8 to 20	2 to 5	See specifications.	Q	See specifications.	See specifications.	C7	M						
GP							12 to 60	Q	C3	F, S				
HG	12 to 60	Q	C5	F, H										

- For more details, refer to the specifications and data for each size.

□ Screw shaft diameter and lead combinations

Screw shaft diameter (mm)	Lead (mm)														
	1	2	3	4	5	10	12	15	16	20	25	30	32	40	60
6	○														
8	○	●○		●			□								
10		●○		●		◆◆									
12		●○	○	●	●	◆◆				◆◆		□			
14				○											
15		●		●	◆◆	◆◆		●		●□◆				□	
16									●				□		
20				●	●	◆◆				●□◆		□		□	□
25					◆◆	◆◆				●	◆◆				
32					●	●									

- : GP, GG, GE series
- : DP series (small lead)
- : HG series (large lead)
- ◆: FG, FE series (high rotational speed)

DP series (Accuracy grade C3)

• Ball screw specifications

Shaft diameter (mm) - Lead (mm)	6 - 1	
Number of circuits / Thread direction	1 turn 3 circuits / Right-hand	
Ball diameter (mm)	0.8	
Root diameter (mm)	5.3	
Series	DP	
Basic dynamic load rating C (N)	550	
Basic static load rating C0 (N)	1150	
Accuracy grade / Axial clearance symbol	C3 / S	C3 / F
Axial clearance (mm)	0	0.005 or less
Preload torque (N·cm)	Up to 1.3	Up to 0.5
Spacer ball	None	
Recirculation system	Deflector method	
Wiper	None	
Lubricant	Multemp PS2	

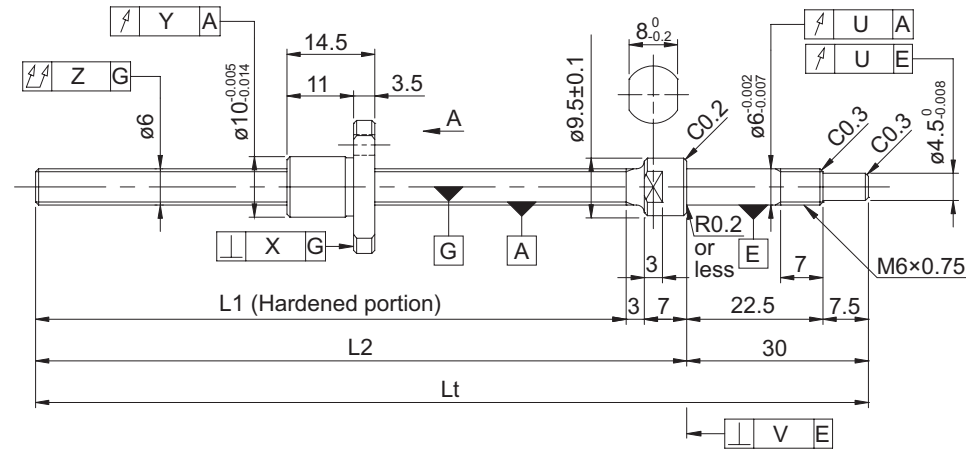
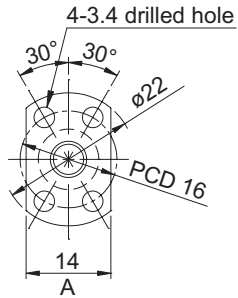

Model No. (One shaft end finished)	Screw shaft length			Maximum stroke (L1 - nut length)	Lead accuracy		
	L1	L2	Lt		±E _c	e _c	e ₃₀₀
DP0601JS-HDNR-0130B-C3S	90	100	130	75	0.012	0.008	0.008
DP0601JS-HDNR-0130B-C3F							
DP0601JS-HDNR-0210B-C3S	170	180	210	155	0.012	0.008	0.008
DP0601JS-HDNR-0210B-C3F							

- Product with axial clearance of 0.005 or less (F) shown may be partially preloaded.
- Preload torque is a value before applying grease.
- At the time of delivery, grease is inserted inside of the nut, with rust-preventive oil also applied. Before and during use, apply lubricant where appropriate.

Screw shaft diameter ø6, Lead 1

• Shaft end finish type

Standard precision ball screws are available with KURODA's recommended shaft end finish types for each size. The fixed end type is finished beforehand.

Regarding the supported shaft end, KURODA's recommended shaft end finish types are not available. Regarding additional machining of the overall length, please contact KURODA with your orders.

Model example: Finished fixed end (See left figure) → Both shaft ends finished
 DP0601JS-HDNR-0210B-C3F → DP0601JS-HDNR-0210X0170-C3F
 ↳ Overall screw shaft length ↳ Thread length

Applicable supported end support unit	Applicable fixed end support unit
----	BUK-6 (Square type)
	BUM-6, BUM-6F (Round type)

• Optional specifications

- Anticorrosive black coating (coating thickness: 1 to 2 μm) is available.

Accuracy of each part					Preload torque (N·cm)		Mass (kg)
X	Y	Z	U	V	Without clearance	With clearance	
0.008	0.008	0.025	0.008	0.0025	Up to 1.3	----	0.04
					----	Up to 0.5	
0.008	0.008	0.035	0.008	0.0025	Up to 1.3	----	0.05
					----	Up to 0.5	

DP series (Accuracy grade C3)

Ball screw specifications

Shaft diameter (mm) - Lead (mm)	8 - 1	
Number of circuits / Thread direction	1 turn 3 circuits / Right-hand	
Ball diameter (mm)	0.8	
Root diameter (mm)	7.3	
Series	DP	
Basic dynamic load rating C (N)	650	
Basic static load rating C0 (N)	1600	
Accuracy grade / Axial clearance symbol	C3 / S	C3 / F
Axial clearance (mm)	0	0.005 or less
Preload torque (N·cm)	Up to 1.8	Up to 0.5
Spacer ball	None	
Recirculation system	Deflector method	
Wiper	None	
Lubricant	Multemp PS2	

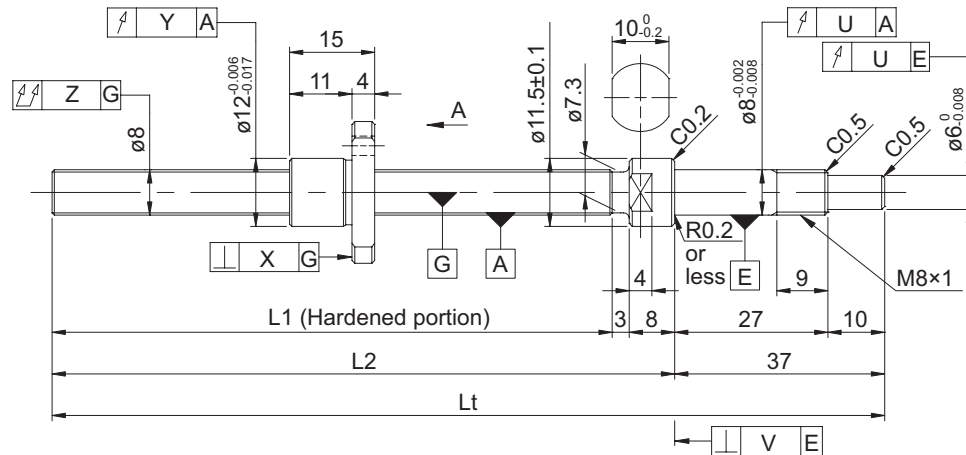
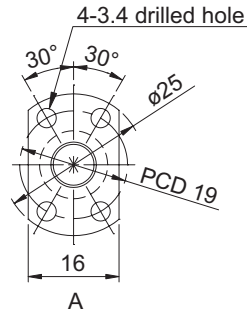

Model No. (One shaft end finished)	Screw shaft length			Maximum stroke (L1 - nut length)	Lead accuracy		
	L1	L2	Lt		±E _c	e _c	e ₃₀₀
DP0801JS-HDNR-0180B-C3S	132	143	180	117	0.010	0.008	0.008
DP0801JS-HDNR-0180B-C3F							
DP0801JS-HDNR-0260B-C3S	212	223	260	197	0.010	0.008	0.008
DP0801JS-HDNR-0260B-C3F							

- Product with axial clearance of 0.005 or less (F) shown may be partially preloaded.
- Preload torque is a value before applying grease.
- At the time of delivery, grease is inserted inside of the nut, with rust-preventive oil also applied. Before and during use, apply lubricant where appropriate.

Screw shaft diameter ø8, Lead 1

Shaft end finish type

Standard precision ball screws are available with KURODA's recommended shaft end finish types for each size. The fixed end type is finished beforehand. Regarding the supported shaft end, additional machining to KURODA's recommended shaft end finish type described below is available. Please contact KURODA with your orders. Model examples for finished shaft ends are described below.

Model example: Finished fixed end (See left figure) → Both shaft ends finished
 DP0801JS-HDNR-0260B-C3F → DP0801JS-HDNR-0260X0203-C3F

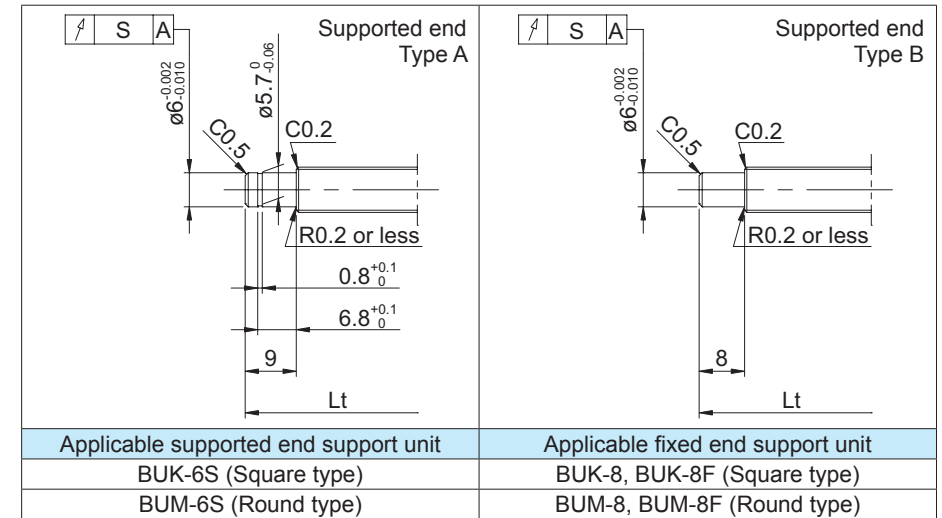

Optional specifications

- Anticorrosive black coating (coating thickness: 1 to 2 μm) is available.

Accuracy of each part						Preload torque (N·cm)		Mass (kg)
X	Y	Z	S	U	V	Without clearance	With clearance	
0.008	0.008	0.030	0.010	0.008	0.0025	Up to 1.8	----	0.08
						----	Up to 0.5	
0.008	0.008	0.035	0.010	0.008	0.0025	Up to 1.8	----	0.11
						----	Up to 0.5	

DP series (Accuracy grade C3)

Ball screw specifications

Shaft diameter (mm) - Lead (mm)	8 - 2	
Number of circuits / Thread direction	1 turn 3 circuits / Right-hand	
Ball diameter (mm)	1.2	
Root diameter (mm)	7.0	
Series	DP	
Basic dynamic load rating C (N)	1350	
Basic static load rating C0 (N)	2300	
Accuracy grade / Axial clearance symbol	C3 / S	C3 / F
Axial clearance (mm)	0	0.005 or less
Preload torque (N·cm)	Up to 2.0	Up to 0.5
Spacer ball	None	
Recirculation system	Deflector method	
Wiper	None	
Lubricant	Multemp PS2	

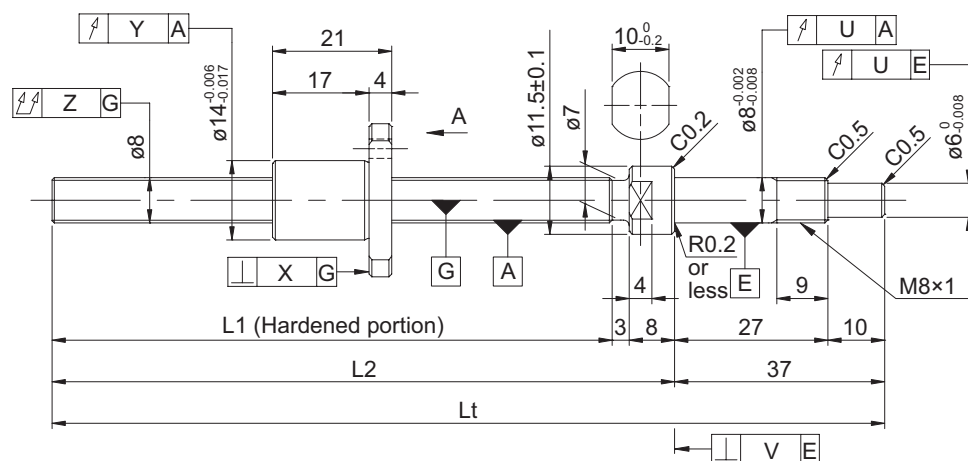
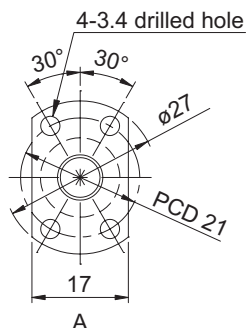

Model No. (One shaft end finished)	Screw shaft length			Maximum stroke (L1 - nut length)	Lead accuracy		
	L1	L2	Lt		±E _c	e _c	e ₃₀₀
DP0802JS-HDNR-0180B-C3S	132	143	180	111	0.012	0.008	0.008
DP0802JS-HDNR-0180B-C3F							
DP0802JS-HDNR-0260B-C3S	212	223	260	191	0.012	0.008	0.008
DP0802JS-HDNR-0260B-C3F							

- Product with axial clearance of 0.005 or less (F) shown may be partially preloaded.
- Preload torque is a value before applying grease.
- At the time of delivery, grease is inserted inside of the nut, with rust-preventive oil also applied. Before and during use, apply lubricant where appropriate.

Screw shaft diameter ø8, Lead 2

Shaft end finish type

Standard precision ball screws are available with KURODA's recommended shaft end finish types for each size. The fixed end type is finished beforehand.

Regarding the supported shaft end, additional machining to KURODA's recommended shaft end finish type described below is available. Please contact KURODA with your orders. Model examples for finished shaft ends are described below.

Model example: Finished fixed end (See left figure) → Both shaft ends finished
 DP0802JS-HDNR-0260B-C3F → DP0802JS-HDNR-0260X0203-C3F

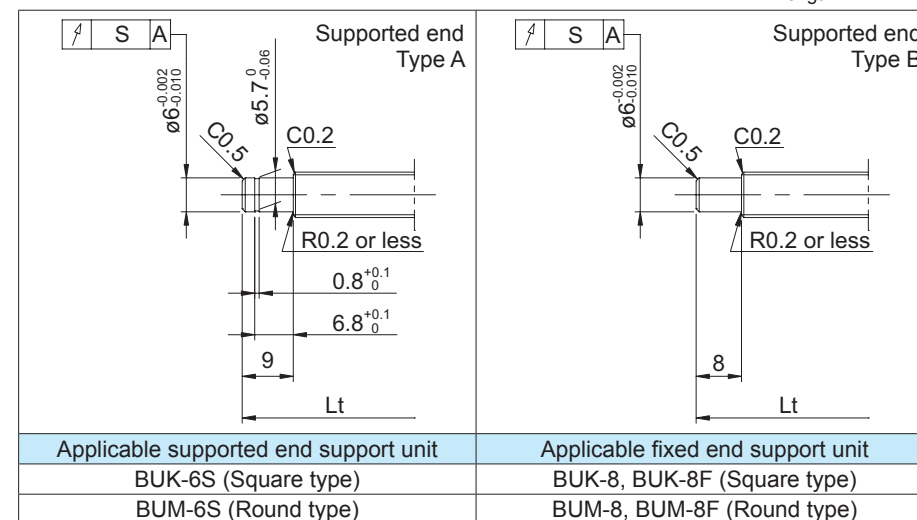

Optional specifications

- Anticorrosive black coating (coating thickness: 1 to 2 μm) is available.

Accuracy of each part						Preload torque (N·cm)		Mass (kg)
X	Y	Z	S	U	V	Without clearance	With clearance	
0.008	0.009	0.030	0.010	0.008	0.0025	Up to 2.0	----	0.09
						----	Up to 0.5	
0.008	0.009	0.035	0.010	0.008	0.0025	Up to 2.0	----	0.11
						----	Up to 0.5	

DP series (Accuracy grade C3)

Ball screw specifications

Shaft diameter (mm) - Lead (mm)	10 - 2	
Number of circuits / Thread direction	1 turn 3 circuits / Right-hand	
Ball diameter (mm)	1.2	
Root diameter (mm)	9.0	
Series	DP	
Basic dynamic load rating C (N)	1550	
Basic static load rating C0 (N)	3000	
Accuracy grade / Axial clearance symbol	C3 / S	C3 / F
Axial clearance (mm)	0	0.005 or less
Preload torque (N·cm)	0.1 to 2.4	Up to 0.5
Spacer ball	None	
Recirculation system	Deflector method	
Wiper	None	
Lubricant	Multemp PS2	

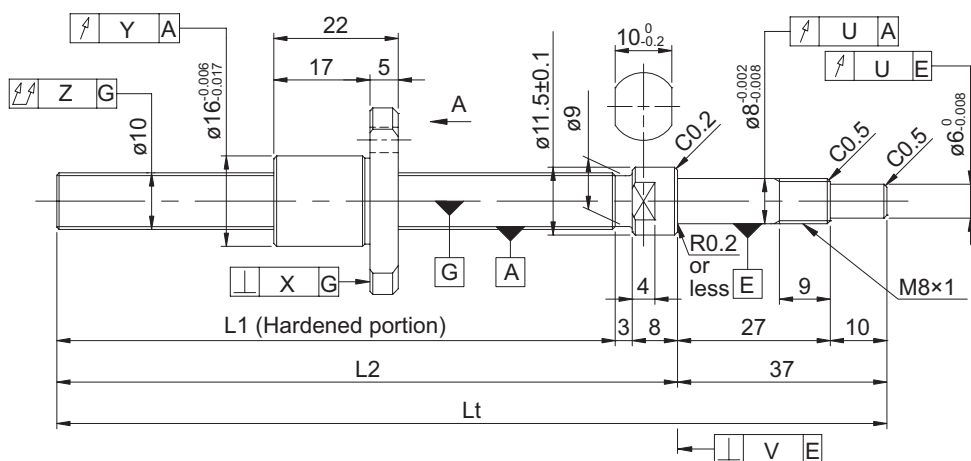
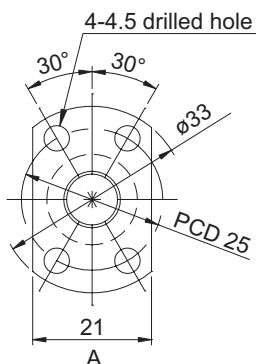

Model No. (One shaft end finished)	Screw shaft length			Maximum stroke (L1 - nut length)	Lead accuracy		
	L1	L2	Lt		$\pm E_c$	e_c	e_{300}
DP1002JS-HDNR-0220B-C3S	172	183	220	150	0.010	0.008	0.008
DP1002JS-HDNR-0220B-C3F							
DP1002JS-HDNR-0320B-C3S	272	283	320	250	0.012	0.008	0.008
DP1002JS-HDNR-0320B-C3F							

- Product with axial clearance of 0.005 or less (F) shown may be partially preloaded.
- Preload torque is a value before applying grease.
- At the time of delivery, grease is inserted inside of the nut, with rust-preventive oil also applied. Before and during use, apply lubricant where appropriate.

Screw shaft diameter $\phi 10$, Lead 2

Shaft end finish type

Standard precision ball screws are available with KURODA's recommended shaft end finish types for each size. The fixed end type is finished beforehand.

Regarding the supported shaft end, additional machining to KURODA's recommended shaft end finish type described below is available. Please contact KURODA with your orders. Model examples for finished shaft ends are described below.

Model example: Finished fixed end (See left figure) → Both shaft ends finished
DP1002JS-HDNR-0320B-C3F → DP1002JS-HDNR-0320X0263-C3F

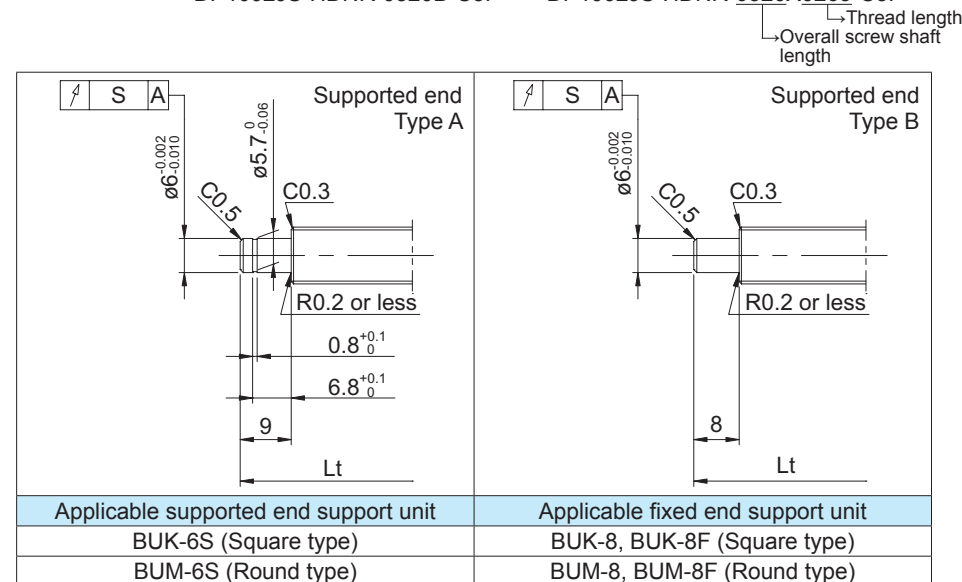

Optional specifications

- Anticorrosive black coating (coating thickness: 1 to 2 μm) is available.

Accuracy of each part						Preload torque (N·cm)		Mass (kg)
X	Y	Z	S	U	V	Without clearance	With clearance	
0.008	0.009	0.030	0.011	0.007	0.0025	0.1 to 2.4	----	0.15
						----	Up to 0.5	
0.008	0.009	0.040	0.011	0.007	0.0025	0.1 to 2.4	----	0.20
						----	Up to 0.5	

DP series (Accuracy grade C3)

Ball screw specifications

Shaft diameter (mm) - Lead (mm)	12 - 2	
Number of circuits / Thread direction	1 turn 3 circuits / Right-hand	
Ball diameter (mm)	1.2	
Root diameter (mm)	11.0	
Series	DP	
Basic dynamic load rating C (N)	1650	
Basic static load rating C0 (N)	3600	
Accuracy grade / Axial clearance symbol	C3 / S	C3 / F
Axial clearance (mm)	0	0.005 or less
Preload torque (N·cm)	0.4 to 3.4	Up to 0.5
Spacer ball	None	
Recirculation system	Deflector method	
Wiper	None	
Lubricant	Multemp PS2	

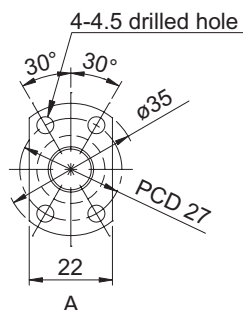

Shaft end finish type

Standard precision ball screws are available with KURODA's recommended shaft end finish types for each size. The fixed end type is finished beforehand.

Regarding the supported shaft end, additional machining to KURODA's recommended shaft end finish type described below is available. Please contact KURODA with your orders. Model examples for finished shaft ends are described below.

Model example: Finished fixed end (See left figure) → Both shaft ends finished
 DP1202JS-HDNR-0400B-C3F → DP1202JS-HDNR-0400X0332-C3F

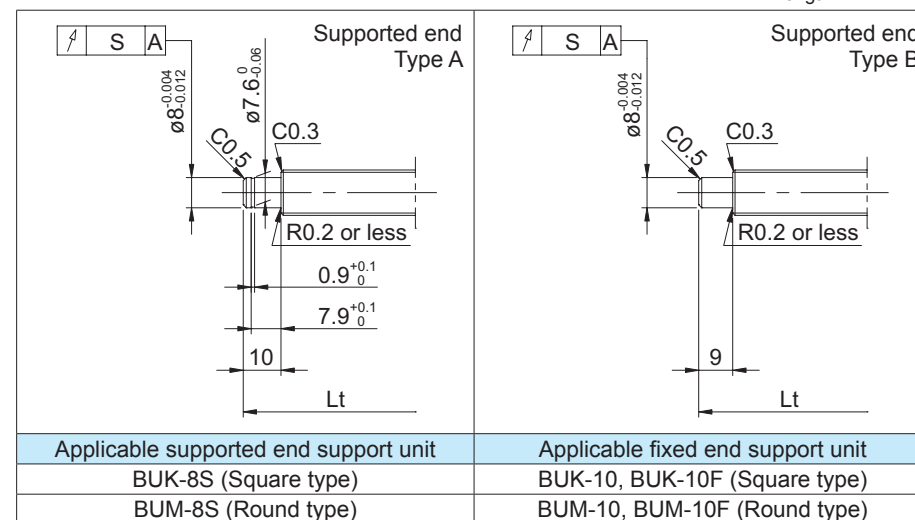

Optional specifications

- Anticorrosive black coating (coating thickness: 1 to 2 μm) is available.

Accuracy of each part						Preload torque (N·cm)		Mass (kg)
X	Y	Z	S	U	V	Without clearance	With clearance	
0.008	0.009	0.030	0.011	0.007	0.003	0.4 to 3.4	----	0.28
						----	Up to 0.5	
0.008	0.009	0.040	0.011	0.007	0.003	0.4 to 3.4	----	0.36
						----	Up to 0.5	

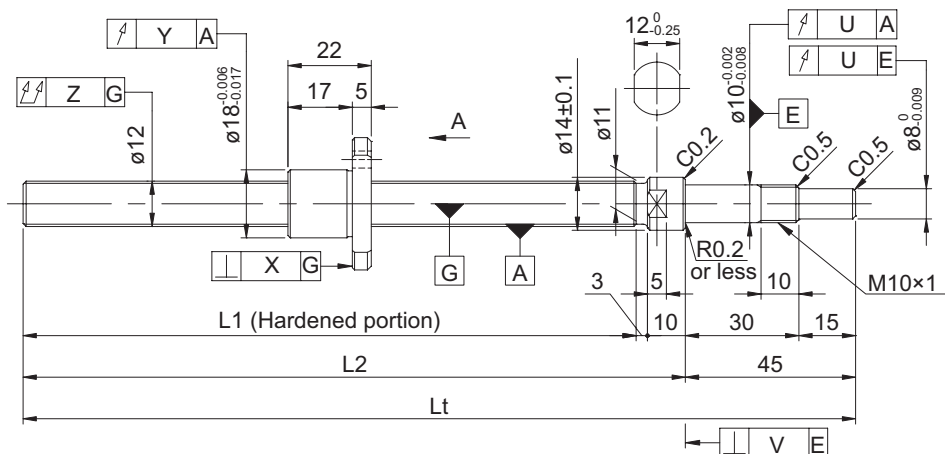

Model No. (One shaft end finished)	Screw shaft length			Maximum stroke (L1 - nut length)	Lead accuracy		
	L1	L2	Lt		±Ec	ec	e300
DP1202JS-HDNR-0300B-C3S	242	255	300	220	0.012	0.008	0.008
DP1202JS-HDNR-0300B-C3F							
DP1202JS-HDNR-0400B-C3S	342	355	400	320	0.013	0.010	0.008
DP1202JS-HDNR-0400B-C3F							

- Product with axial clearance of 0.005 or less (F) shown may be partially preloaded.
- Preload torque is a value before applying grease.
- At the time of delivery, grease is inserted inside of the nut, with rust-preventive oil also applied. Before and during use, apply lubricant where appropriate.

DP series (Accuracy grade C3)

Ball screw specifications

Shaft diameter (mm) - Lead (mm)	12 - 3	
Number of circuits / Thread direction	1 turn 3 circuits / Right-hand	
Ball diameter (mm)	2	
Root diameter (mm)	10.3	
Series	DP	
Basic dynamic load rating C (N)	3450	
Basic static load rating C0 (N)	6100	
Accuracy grade / Axial clearance symbol	C3 / S	C3 / F
Axial clearance (mm)	0	0.005 or less
Preload torque (N·cm)	0.4 to 3.4	Up to 1.0
Spacer ball	None	
Recirculation system	Deflector method	
Wiper	Plastic wiper	
Lubricant	Multemp PS2	

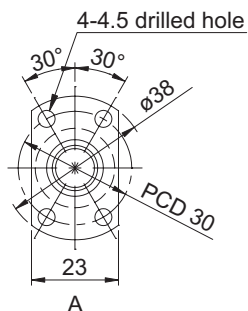

Shaft end finish type

Standard precision ball screws are available with KURODA's recommended shaft end finish types for each size. The fixed end type is finished beforehand.

Regarding the supported shaft end, additional machining to KURODA's recommended shaft end finish type described below is available. Please contact KURODA with your orders. Model examples for finished shaft ends are described below.

Model example: Finished fixed end (See left figure) → Both shaft ends finished

DP1203JS-HDPR-0400B-C3F → DP1203JS-HDPR-0400X0330-C3F

Overall screw shaft length
Thread length

Supported end Type A	Supported end Type B
Applicable supported end support unit	Applicable fixed end support unit
BUK-8S (Square type)	BUK-10, BUK-10F (Square type)
BUM-8S (Round type)	BUM-10, BUM-10F (Round type)

Optional specifications

- Anticorrosive black coating (coating thickness: 1 to 2 μm) is available.

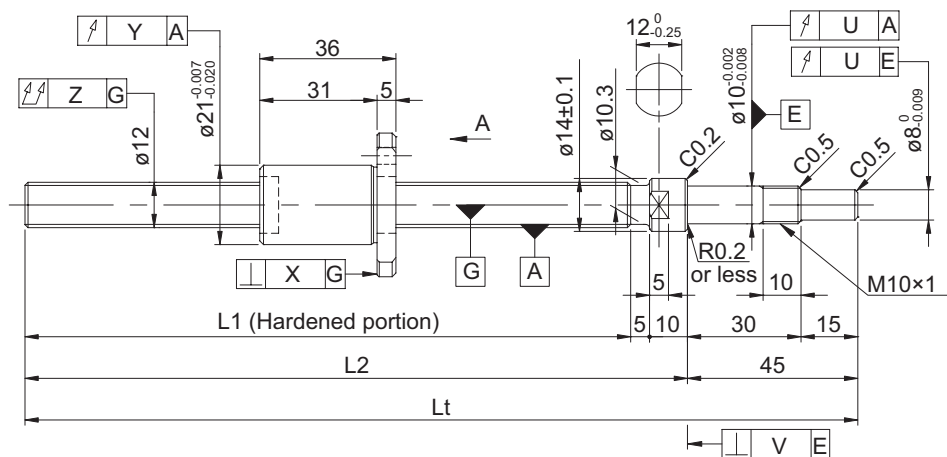

Model No. (One shaft end finished)	Screw shaft length			Maximum stroke (L1 - nut length)	Lead accuracy		
	L1	L2	Lt		±E _c	e _c	e ₃₀₀
DP1203JS-HDPR-0300B-C3S	240	255	300	204	0.012	0.008	0.008
DP1203JS-HDPR-0300B-C3F							
DP1203JS-HDPR-0400B-C3S	340	355	400	304	0.013	0.010	0.008
DP1203JS-HDPR-0400B-C3F							

- Product with axial clearance of 0.005 or less (F) shown may be partially preloaded.
- Preload torque is a value before applying grease.
- At the time of delivery, grease is inserted inside of the nut, with rust-preventive oil also applied. Before and during use, apply lubricant where appropriate.

DP series (Accuracy grade C3)

● Ball screw specifications

Shaft diameter (mm) - Lead (mm)	14 - 4	
Number of circuits / Thread direction	1 turn 3 circuits / Right-hand	
Ball diameter (mm)	2.3812	
Root diameter (mm)	12.1	
Series	DP	
Basic dynamic load rating C (N)	4600	
Basic static load rating C0 (N)	8600	
Accuracy grade / Axial clearance symbol	C3 / S	C3 / F
Axial clearance (mm)	0	0.005 or less
Preload torque (N·cm)	1.0 to 6.9	Up to 1.5
Spacer ball	None	
Recirculation system	Deflector method	
Wiper	Plastic wiper	
Lubricant	Multemp PS2	

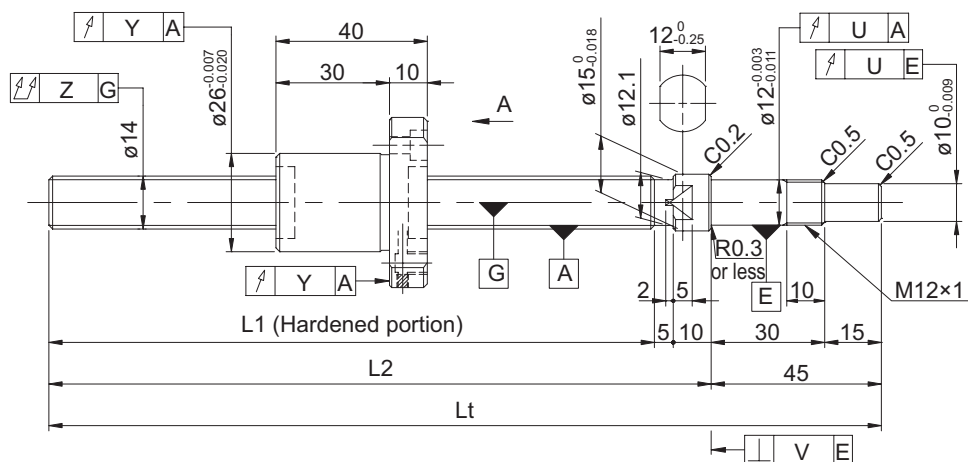
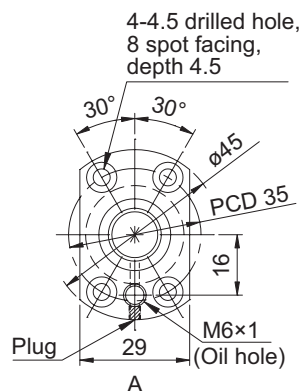

Model No. (One shaft end finished)	Screw shaft length			Maximum stroke (L1 - nut length)	Lead accuracy		
	L1	L2	Lt		$\pm e_c$	e_c	e_{300}
DP1404JS-HDPR-0330B-C3S	270	285	330	230	0.012	0.008	0.008
DP1404JS-HDPR-0330B-C3F							
DP1404JS-HDPR-0530B-C3S	470	485	530	430	0.015	0.010	0.008
DP1404JS-HDPR-0530B-C3F							

- Product with axial clearance of 0.005 or less (F) shown may be partially preloaded.
- Preload torque is a value before applying grease.
- At the time of delivery, grease is inserted inside of the nut, with rust-preventive oil also applied. Before and during use, apply lubricant where appropriate.

Screw shaft diameter $\phi 14$, Lead 4

● Shaft end finish type

Standard precision ball screws are available with KURODA's recommended shaft end finish types for each size. The fixed end type is finished beforehand.

Regarding the supported shaft end, additional machining to KURODA's recommended shaft end finish type described below is available. Please contact KURODA with your orders. Model examples for finished shaft ends are described below.

Model example: Finished fixed end (See left figure) → Both shaft ends finished
 DP1404JS-HDPR-0530B-C3F → DP1404JS-HDPR-0530X0458-C3F

Supported end Type A	Supported end Type B
Applicable supported end support unit	Applicable fixed end support unit
BUK-10S (Square type)	BUK-12, BUK-12F (Square type)
BUM-10S (Round type)	BUM-12, BUM-12F (Round type)

● Optional specifications

- Anticorrosive black coating (coating thickness: 1 to 2 μm) is available.

Accuracy of each part						Preload torque (N·cm)		Mass (kg)
X	Y	Z	S	U	V	Without clearance	With clearance	
0.008	0.010	0.030	0.012	0.009	0.004	1.0 to 6.9	----	0.48
						----	Up to 1.5	
0.008	0.010	0.045	0.012	0.009	0.004	1.0 to 6.9	----	0.69
						----	Up to 1.5	