

Order Made (Not Stocked)

Miniature Flanged Ball Screws AZ/DZ/GT

- Shaft length and shaft end design are customizable

Overall shaft length and thread length can be dictated to 1 mm increments

- Ground thread finish options available
- Ground ball screws are ideal for applications that require precision positioning

- Flange design is customizable

Flange dimensions, shape, and features can be freely aligned to customers' design requirements



Technical Specifications

Model Number	Nominal Diameter [mm]	Lead [mm]	Ball Diameter [mm]	Number of Circuits	Basic Dynamic Load Rating [N]	Basic Static Load Rating [N]	Accuracy Grade
GT0601HS	6	1	0.800	1×2	390	770	C10
DZ0601HS		1	0.800	1×2	390	770	
DZ0602HS		2	1.000	1×2	540	760	Contact us for details
AZ06064S		6	1.200	1.7×2	1,310	1,650	
AZ06084S		8	1.200	1.7×2	1,250	1,600	
GT0801HS	8	1	0.800	1×2	460	1,070	C7 / C10
DZ0801HS		1	0.800	1×2	460	1,070	
DZ0802HS		2	1.200	1×2	950	1,530	Contact us for details
AZ08124S		12	1.5875	1.7×2	2,000	2,730	
AZ10053S		5	2.381	2.7×1	3,940	5,140	
AZ10102S	10	10	2.3812	1.7×1	2,540	3,130	Contact us for details
AZ12053S		5	2.3812	2.7×1	4,250	5,980	
AZ12103S	12	10	2.3812	2.7×1	4,300	6,200	Contact us for details
AZ12202S		20	2.3812	1.7×1	2,700	3,800	

Shape / Dimensions

[Unit: mm]

Model Number	Body Diameter D	Total Length LT	Thickness T	Nut Dimensions				Mounting Hole M	Flange Position
				Diameter D1	Width X	PCD			
GT0601HS	10	13	4	22	11	16	For M3	A	
DZ0601HS	10	12	3					A	
DZ0602HS	10	14	3					TBD	A
AZ06064S	12	16	3						B
AZ06084S	12	20	3						B
GT0801HS	12	15	4	24	13	18	For M3	A	
DZ0801HS	12	13	4					A	
DZ0802HS	14	17	4					TBD	A
AZ08124S	16	28	4						B
AZ10053S	23	24	11						A
AZ10102S	23	29	11	TBD	A				
AZ12053S	24	35	11		A				
AZ12103S	24	38	11		A				
AZ12202S	24	48	11		A				

*The shape and features of the flange to be determined through technical consultation.

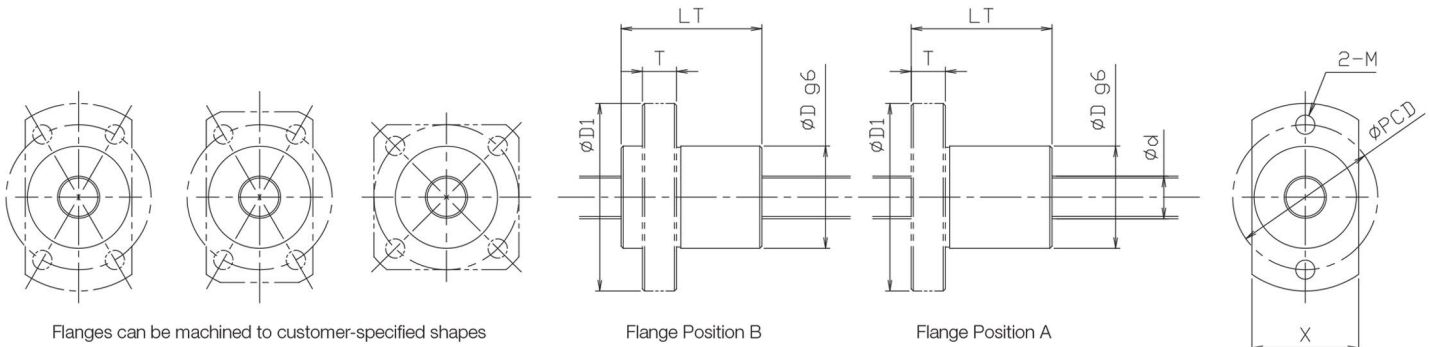

Flanges can be machined to customer-specified shapes

Flange Position B

Flange Position A